

USER'S MANUAL

BM161/BM162 Versatile AC/DC Clamp-on Multimeter Series



1) SAFETY

This manual contains information and warnings that must be followed for operating the instrument safely and maintaining the instrument in a safe operating condition. If the instrument is used in a manner not specified by the manufacturer, the protection provided by the instrument may be impaired.

The meter meets the requirements for double insulation to IEC61010-2-032(2002), EN61010-2-032(2002), UL61010B-2-032(2003):
Category III 600 Volts ac and dc.

PER IEC61010 OVERVOLTAGE INSTALLATION CATEGORY

OVERVOLTAGE CATEGORY II

Equipment of OVERVOLTAGE CATEGORY II is energy-consuming equipment to be supplied from the fixed installation.

Note – Examples include household, office, and laboratory appliances.

OVERVOLTAGE CATEGORY III

Equipment of OVERVOLTAGE CATEGORY III is equipment in fixed installations.

Note – Examples include switches in the fixed installation and some equipment for industrial use with permanent connection to the fixed installation.

OVERVOLTAGE CATEGORY IV

Equipment of OVERVOLTAGE CATEGORY IV is for use at the origin of the installation. Note – Examples include electricity meters and primary over-current protection equipment.

TERMS IN THIS MANUAL

WARNING identifies conditions and actions that could result in serious injury or even death to the user.

CAUTION identifies conditions and actions that could cause damage or malfunction in the instrument.

WARNING

To reduce the risk of fire or electric shock, do not expose this product to rain or moisture. The meter is intended only for indoor use.

To avoid electrical shock hazard, observe the proper safety precautions when working with voltages above 60 VDC or 30 VAC rms. These voltage levels pose a potential shock hazard to the user.









Keep your hands/fingers behind the hand/finger barriers (of the meter and the test leads) that indicate the limits of safe access of the hand-held part during measurement. Inspect test leads, connectors, and probes for damaged insulation or exposed metal before using the instrument. If any defects are found, replace them immediately.

This Clamp-on meter is designed to apply around or remove from uninsulated hazardous live conductors. But still, individual protective equipment must be used if hazardous live parts in the installation where measurement is to be carried out could be accessible.

CAUTION

Disconnect the test leads from the test points before changing meter functions.

INTERNATIONAL ELECTRICAL SYMBOLS

	Caution ! Refer to the explanation in this Manual
	Caution ! Risk of electric shock
	Earth (Ground)
	Double Insulation or Reinforced insulation
	Fuse
	AC--Alternating Current
	DC--Direct Current
	Application around and removal from hazardous live conductors is permitted

2) CENELEC Directives

The instruments conform to CENELEC Low-voltage directive 73/23/EEC and Electromagnetic compatibility directive 89/336/EEC

3) PRODUCT DESCRIPTION

This user's manual uses only representative model(s) for illustrations. Please refer specification details for function availability to each model.

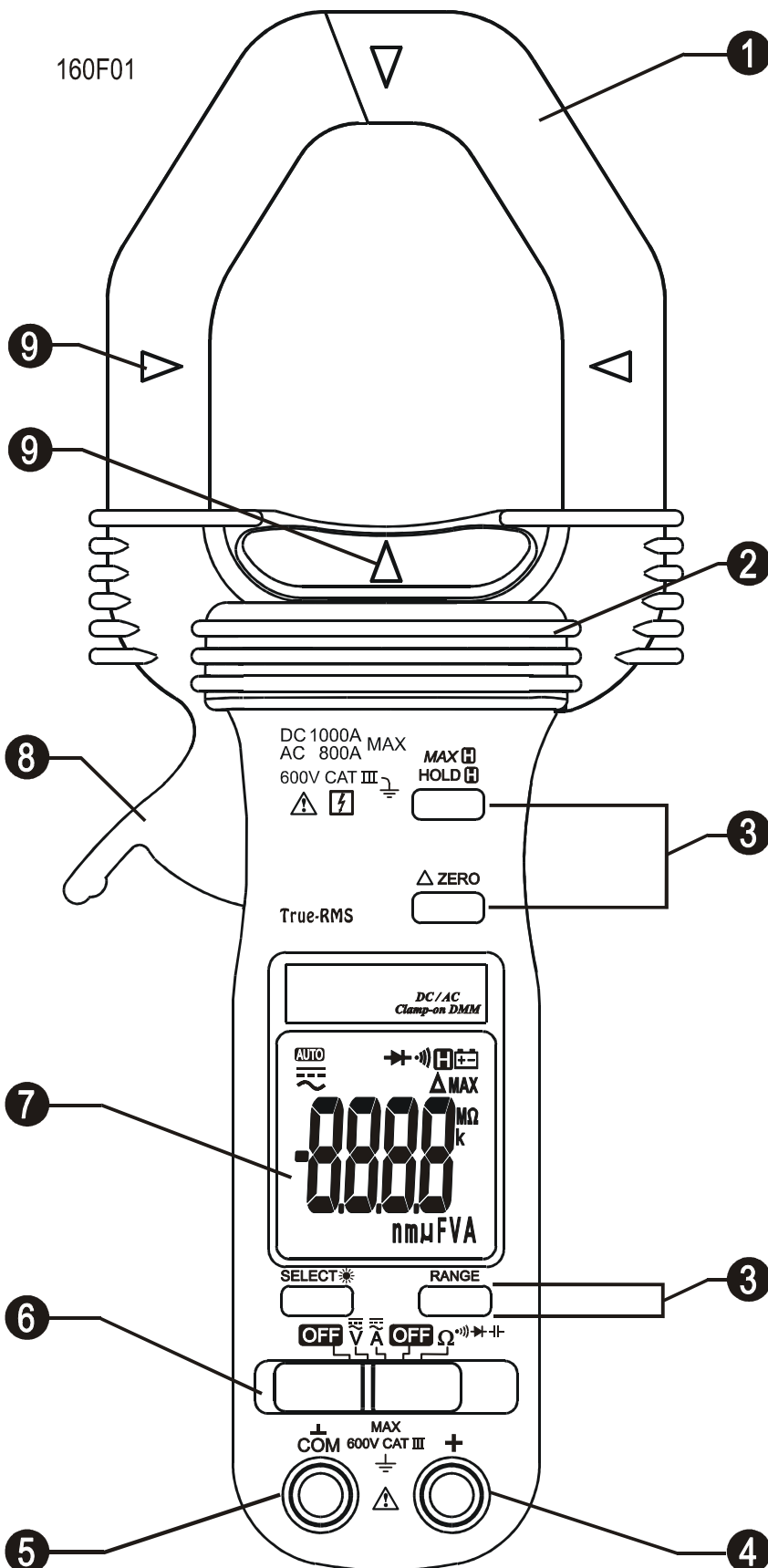

1) Hall-effect Clamp Jaw for AC & DC current electric field pick up

2) Hand/Finger Barrier to indicate the limits of safe access of the meter during measurement

3) Push-buttons for special functions & features

4) Input Jack for all functions EXCEPT non-invasive ACA & DCA current functions

5) Common (Ground reference) Input Jack for all functions EXCEPT non-invasive ACA & DCA current functions

6) Slide-switch Selector to turn the power ON/OFF and Select a function

7) 3-3/4 digits 4000 counts LCD display

8) Jaw trigger for opening the clamp jaw

9) Jaw center Indicators, at where best ACA & DCA accuracy is specified

4) OPERATION

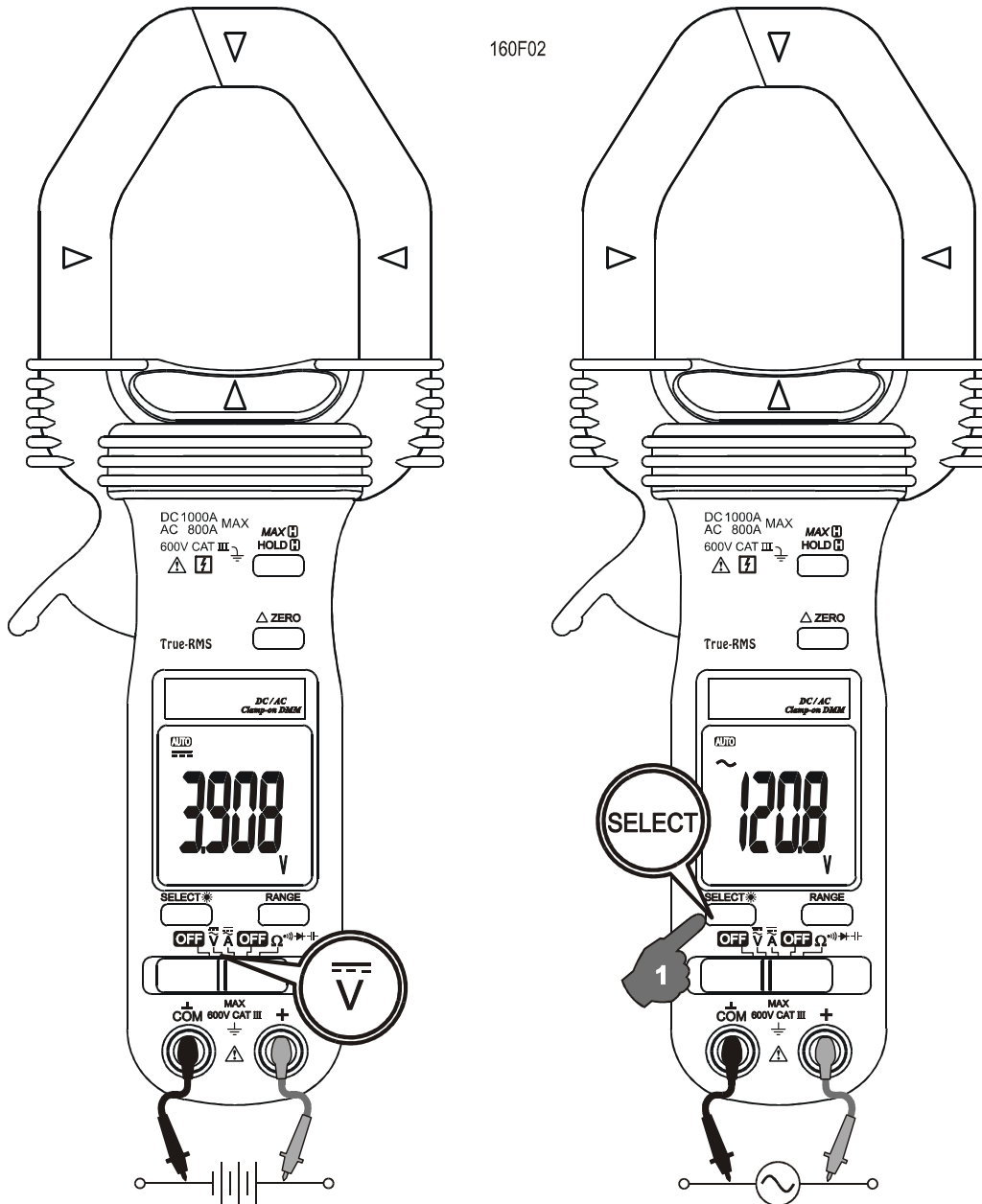

DC Voltage and AC Voltage functions

Inputs are made through the test lead terminals.

Note: DC 400.0mV range is designed with $1000M\Omega$ high input impedance for least current drain in measuring small signals, and can cope better with most commercially available voltage output transducers/adapters. The non-zero display reading is normal when the meter inputs are open circuit, which will not affect actual measurement accuracy. The meter will show a close to zero reading when the inputs are shorted. Open input is actually a floating condition, which is not a zero-volt-input condition.

Note: AC 400.0mV range selection is by RANGE button manually, and is specified from AC 40mV & up for Model 161 and from AC 60mV & up for True RMS Model 162.

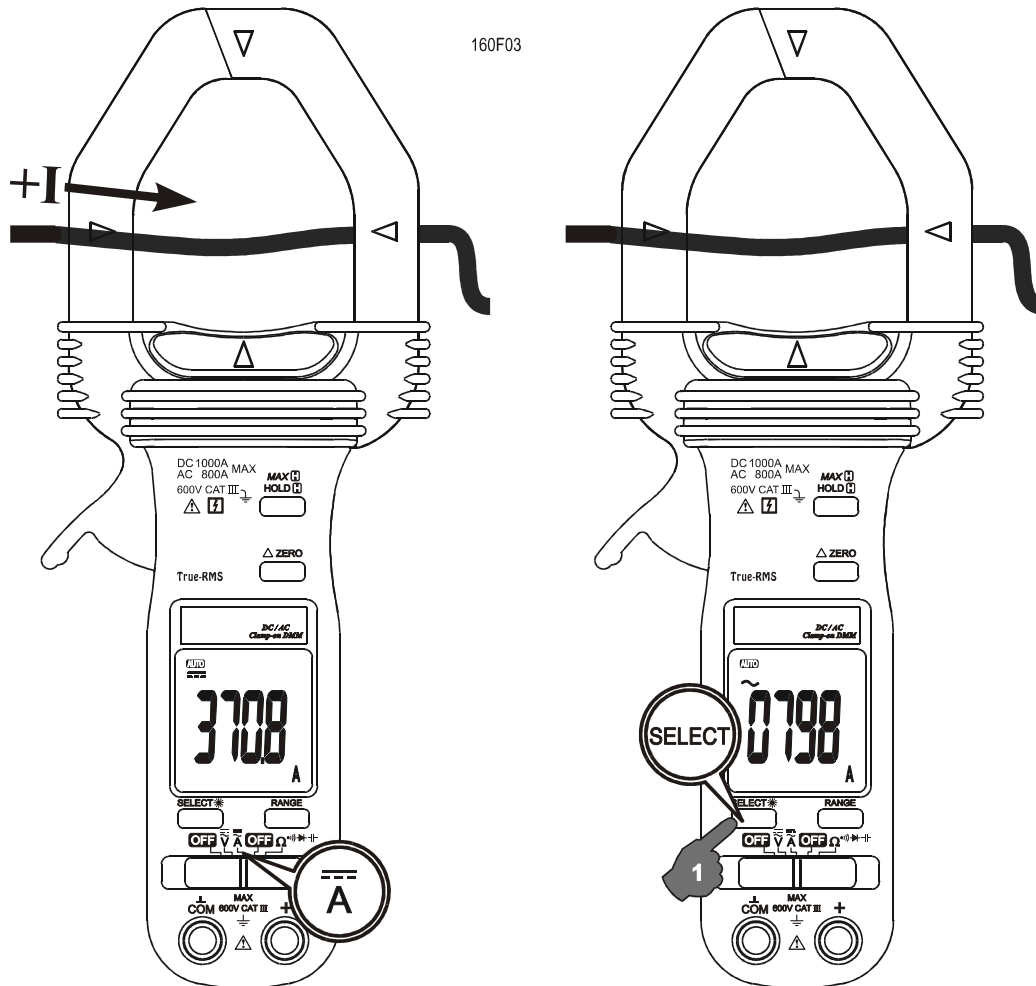

ACA & DCA Current clamp-on function

Inputs are made through the clamp jaws for non-invasive ACA & DCA current measurements.

CAUTION (Application and removal of the Clamp-on meter)

Press the jaw trigger and clamp the jaws around only one single conductor of a circuit for load current measurement. Make sure the jaws are completely closed, or else it will introduce measurement errors. Enclosing more than one conductor of a circuit will result in differential current (like identifying leakage current) measurement. Locate the conductor(s) at the Jaws center as much as possible to get the best measuring accuracy. The jaw arrow-mark indicates current flow direction on DCA positive readings. For removal, press the jaw trigger and remove the jaws from the conductor(s).

Note: In DCA measurements, hysteresis of the jaws (after measuring high DC currents) may introduce non-zero residual readings. Relative Zero Δ mode should be used to offset the residual readings, if any, so as to get more accurate measurements.

Adjacent current-carrying devices such as transformers, motors and conductor wires will affect measurement accuracy. Keep the jaws away from them as much as possible to minimize influence.

160F04

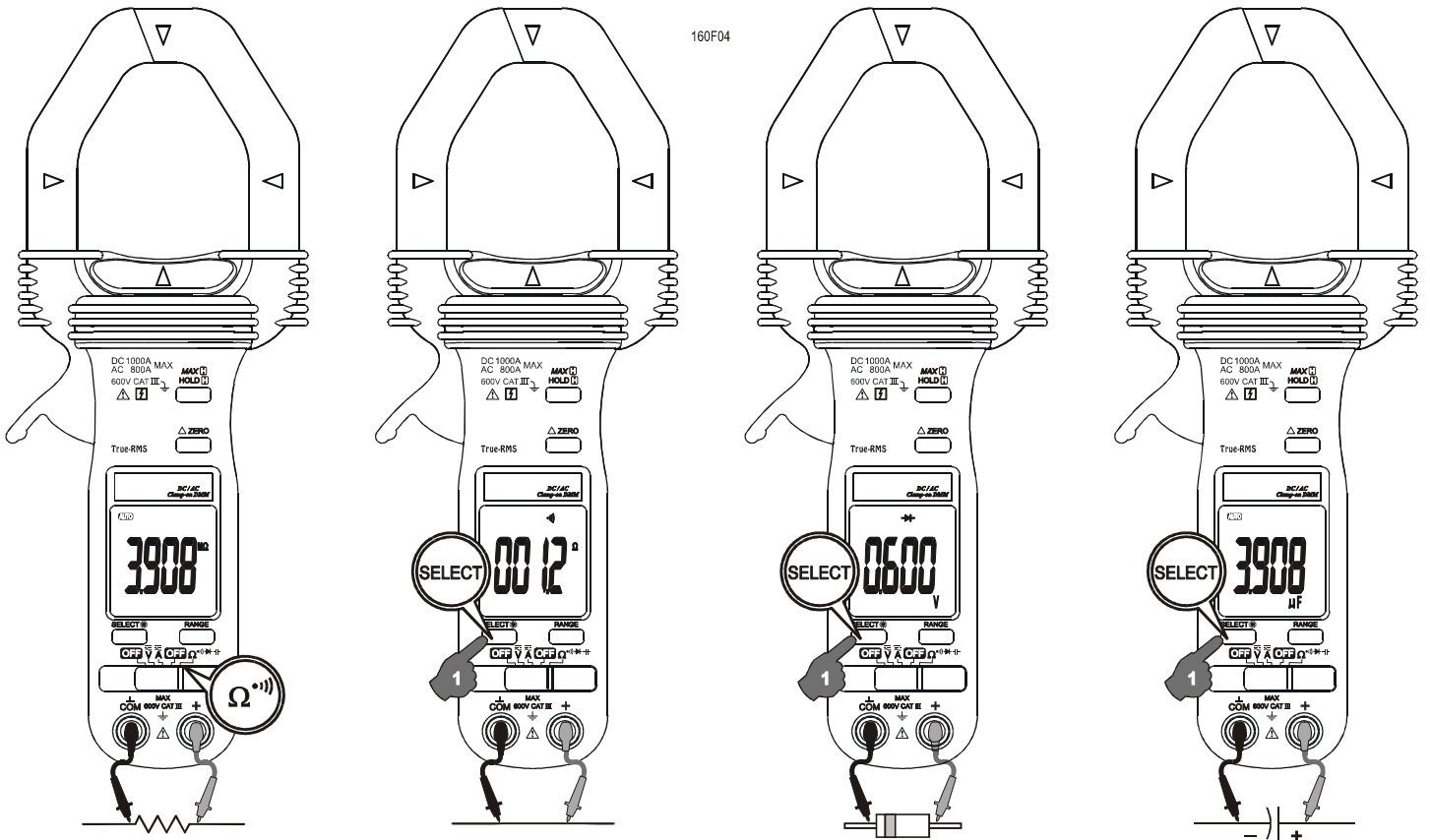

CAUTION

Using Resistance, Continuity or Diode function in a live circuit will produce false results and may damage the instrument. In many cases the suspected component must be disconnected from the circuit to obtain an accurate measurement reading

Ω Resistance, and •)) Continuity functions

Inputs are made through the test leads terminals. Slide-switch on defaults at Ω. Press **SELECT** button momentarily to select •)) Continuity function which is convenient for checking wiring connections and operation of switches. A continuous beep tone indicates a complete wire.

→ Diode test function

Inputs are made through the test leads terminals. Slide-switch on defaults at Ω. Press **SELECT** button momentarily 2 times to select → Diode test function. Normal forward voltage drop (forward biased) for a good silicon diode is between 0.400V to 0.900V. A reading higher than that indicates a leaky diode (defective). A zero reading indicates a shorted diode (defective). An OL indicates an open diode (defective). Reverse the test leads connections (reverse biased) across the diode. The digital display shows OL if the diode is good. Any other readings indicate the diode is resistive or shorted (defective).



-H- Capacitance function

Inputs are made through the test leads terminals. Slide-switch on defaults at Ω . Press **SELECT** button momentarily 3 times to select **-H-** Capacitance function. Relative zero Δ mode can be used to zero out the parasitic capacitance of the leads and the internal protection circuitry of the meter when measuring low capacitance in the order of Pico Farad (pF).



CAUTION

Discharge capacitors before making any measurement. Large value capacitors should be discharged through an appropriate resistance load

HOLD

The Hold feature freezes the display for later viewing. Press the **HOLD**  button momentarily to toggle to the Hold feature. The annunciator " turns on.

MAX

The max feature compares and displays the measured maximum value as fast as 30ms with auto-ranging capability. It allows the meter to capture in-rush currents in current functions. Press and hold the **MAX**  button for 1 second or more to toggle to the max feature. The annunciators "**MAX**" and "" turn on.

Relative Zero Δ mode

Relative Zero Δ mode allows the user to offset the meter consecutive measurements with the displaying reading as the reference value. The display will now show readings relative to the stored reference value. That is, display = reading - stored value. Press the Δ button momentarily to toggle to the relative zero mode. The annunciator " Δ " turns on. The meter also enters manual ranging mode where available. The annunciator "**AUTO**" turns off.

Manual or Auto-ranging

Press the **RANGE** button momentarily to select manual-ranging mode, and the meter will remain in the range it was in, the LCD annunciator "**AUTO**" turns off. Press the button momentarily again to step through the ranges. Press and hold the button for 1 second or more to resume auto-ranging mode.

Display Backlight (Model 162 only)

Press the **SELECT** button for 1 second or more to toggle the display backlight on and off.

Auto Power Off (APO)

When the meter is on, the Auto Power Off (APO) feature will switch the meter to sleep mode automatically after approximately 30 minutes of no slide-switch nor push button operations to extend battery life. To wake up the meter from APO, press any push-buttons momentarily or set the slide-switch to the OFF position and then slide back on again. Always set the slide-switch to the OFF position manually when the meter is not in use.

5) MAINTENANCE

WARNING

To avoid electrical shock, disconnect the meter from any circuit, remove the test leads from the input jacks and turn OFF the meter before opening the case. Do not operate with open case.

Trouble Shooting

If the instrument fails to operate, check batteries and test leads etc., and replace as necessary. Double check operating procedure as described in this user's manual

If the instrument voltage-resistance input terminal has subjected to high voltage transient (caused by lightning or switching surge to the system) by accident or abnormal conditions of operation, the series fusible resistors will be blown off (become high impedance) like fuses to protect the user and the instrument. Most measuring functions through this terminal will then be open circuit. The series fusible resistors and the spark gaps should then be replaced by qualified technician. Refer to the LIMITED WARRANTY section for obtaining warranty or repairing service.

Cleaning and Storage

Periodically wipe the case with a damp cloth and mild detergent; do not use abrasives or solvents. If the meter is not to be used for periods of longer than 60 days, remove the batteries and store them separately

Battery replacement

The meter uses standard 1.5V AAA Size (NEDA 24G or IEC R03) battery X 2; or 1.5V AAA Size (NEDA 24A or IEC LR03) alkaline battery X 2.

Loosen the 2 captive screws from the battery cover case. Lift the battery cover case. Replace the batteries. Replace battery cover case. Re-fasten the screws.

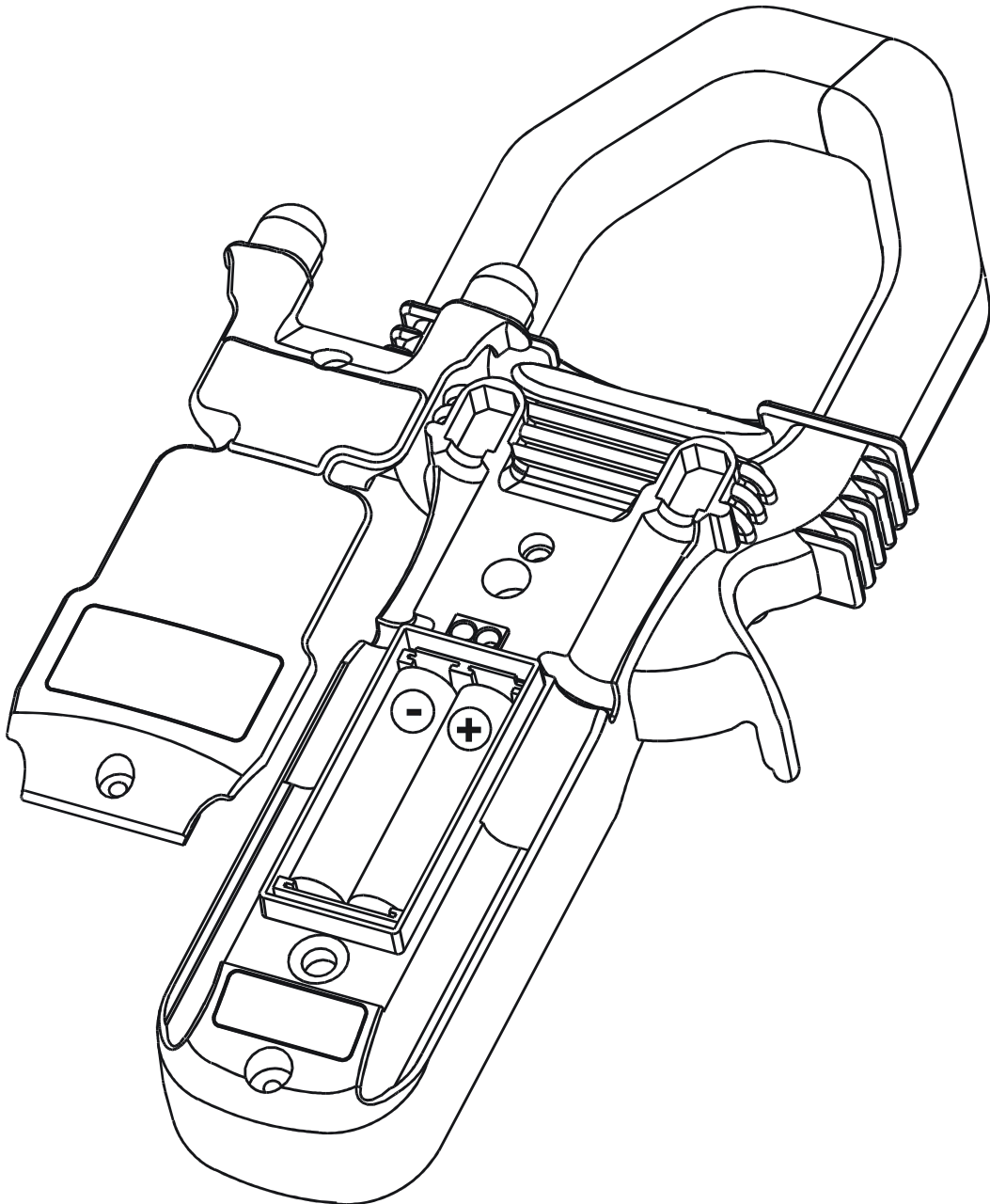

6) SPECIFICATIONS

General Specifications

Display : 3-3/4 digits 4000 counts LCD display(s)

Update Rate : 3 per second nominal

Polarity : Automatic

Low Battery : Below approx. 2.4V

Operating Temperature : 0°C to 40°C

Relative Humidity : Maximum relative humidity 80% for temperature up to 31°C decreasing linearly to 50% relative humidity at 40°C

Altitude : Operating below 2000m

Storage Temperature : -20°C to 60°C, < 80% R.H. (with battery removed)

Temperature Coefficient : nominal $0.15 \times (\text{specified accuracy}) / ^\circ\text{C}$ @ (0°C -18°C or 28°C -40°C), or otherwise specified

Sensing : Average sensing for Model 161; True RMS for Model 162

Safety : Meets IEC61010-2-032(2002), EN61010-2-032(2002), UL61010B-2-032(2003)
Category III 600 Volts ac & dc.

Transient protection : 6.5kV (1.2/50 μ s surge) for all models

Pollution degree : 2

E.M.C. : Meets EN61326(1997, 1998/A1), EN61000-4-2(1995), and EN61000-4-3(1996)

In an RF field of 3V/m:

Capacitance function is not specified

Other function ranges: Total Accuracy = Specified Accuracy + 45 digits

Performance above 3V/m is not specified

Overload Protections :

Clamp-on jaws : DC 1000A or AC 800A rms continuous

+ & COM terminals (all functions) : 600VDC/VAC rms

Power Supply : standard 1.5V AAA Size (NEDA 24G or IEC R03) battery X 2; or 1.5V AAA Size (NEDA 24A or IEC LR03) alkaline battery X 2

Power Consumption : typical 11mA for ACA/DCA and 2.9mA for other functions

APO Timing : Idle for 30 minutes

APO Consumption : typical 10 μ A for Model 161 and 190 μ A for Model 162

Dimension : L227mm X W78mm X H40mm

Weight : 290 gm approx

Jaw opening & Conductor diameter : 50mm max

Accessories : Test lead pair, batteries installed, user's manual & soft carrying pouch

Electrical Specifications

Accuracy is \pm (% reading digits + number of digits) or otherwise specified, at $23^{\circ}\text{C} \pm 5^{\circ}\text{C}$ & less than 75% R.H.

True RMS Model 162 ACV & ACA clamp-on accuracies are specified from 5% to 100% of range or otherwise specified. Maximum Crest Factor are as specified below, and with frequency spectrums, besides fundamentals, fall within the meter specified AC bandwidth for non-sinusoidal waveforms.

DC Voltage

RANGE	Accuracy
400.0 mV	0.3% + 3d
4.000V, 40.00V, 400.0V	0.5% + 3d
600V	1.0% + 4d

NMRR : >50dB @ 50/60Hz

CMRR : >120dB @ DC, 50/60Hz, $R_s=1\text{k}\Omega$

Input Impedance : $10\text{M}\Omega$, 30pF nominal ($1000\text{M}\Omega$ for 400.0mV range)

AC Voltage

RANGE	Accuracy
50Hz ~ 500Hz	
400.0mV ¹⁾	4.0% + 4d
50Hz ~ 60Hz	
4.000V, 40.00V, 400.0V	1.0% + 4d
60Hz ~ 500Hz	
4.000V, 40.00V, 400.0V	1.5% + 4d
50Hz ~ 500Hz	
600V	2.0% + 4d

CMRR : >60dB @ DC to 60Hz, $R_s=1\text{k}\Omega$

Input Impedance: $10\text{M}\Omega$, 30pF nominal

True RMS Model 162 Crest Factor: < 1.6 : 1 at full scale & < 3.2 : 1 at half scale

¹⁾Selection by RANGE button manually, and is specified from AC 40mV (AC 60mV for True RMS Model 162) and up

Ohms

RANGE	Accuracy
400.0Ω	0.8% + 6d
4.000kΩ, 40.00kΩ, 400.0kΩ	0.6% + 4d
4.000MΩ	1.0% + 4d
40.00MΩ	2.0% + 4d

Open Circuit Voltage : 0.4VDC typical

Audible Continuity Tester

Open Circuit Voltage: 0.4VDC typical

Range: 400.0Ω; Accuracy: 1.5% + 6d

Audible threshold: between 10Ω and 120Ω.

Diode Tester

Open Circuit Voltage	Test Current (Typical)
< 1.6 VDC	0.4mA

Capacitance

RANGE ¹⁾	Accuracy ^{2) 3)}
500.0nF, 5.000μF, 50.00μF, 500.0μF, 3000μF	3.5% + 6d

¹⁾Additional 50.00nF range accuracy is not specified

²⁾Accuracies with film capacitor or better

³⁾Specified with battery voltage above 2.8V (approximately half full battery). Accuracy decreases gradually to 12% at low battery warning voltage of approximately 2.4V

DCA Current (Clamp-on)

RANGE	Accuracy ^{1) 2)}
400.0A	
0A ~ 400.0A	1.5% + 4d
1000A	
400A ~ 800A	1.5% + 4d
800A ~ 900A	2.0% + 4d
900A ~ 1000A	5.0% + 30d

¹⁾Induced error from adjacent current-carrying conductor: < 0.01A/A

²⁾Relative Zero Δ mode is applied to offset the non-zero residual readings, if any

ACA Current (Clamp-on)

RANGE	Accuracy^{1) 2)}
400.0A	
15Hz ~ 40Hz	2.0% + 5d ³⁾
40Hz ~ 200Hz	1.5% + 5d
200Hz ~ 400Hz @ <50A ⁴⁾	1.5% + 5d
400Hz ~ 1kHz @ <50A ⁴⁾	2.0% + 5d
800A	
15Hz ~ 40Hz @ 400A ~ 600A	2.0% + 5d ³⁾
40Hz ~ 100Hz @ 400A ~ 600A	1.5% + 4d
15Hz ~ 60Hz @ 600A ~ 800A	5.0% + 30d

¹⁾Induced error from adjacent current-carrying conductor: < 0.01A/A

²⁾True RMS model 162 Crest Factor: < 1.6 : 1 at full scale & < 3.2 : 1 at half scale

³⁾4.0% + 5d for True RMS model 162

⁴⁾Accuracy is specified at <50A in this frequency bandwidth due to limited calibrator output capability for testing

LIMITED WARRANTY

BRYMEN warrants to the original product purchaser that each product it manufactures will be free from defects in material and workmanship under normal use and service within a period of one year from the date of purchase. BRYMEN's warranty does not apply to accessories, fuses, fusible resistors, spark gaps, batteries or any product which, in BRYMEN's opinion, has been misused, altered, neglected, or damaged by accident or abnormal conditions of operation or handling.

To obtain warranty service, contact your nearest BRYMEN authorized agent or send the product, with proof of purchase and description of the difficulty, postage and insurance prepaid, to BRYMEN TECHNOLOGY CORPORATION. BRYMEN assumes no risk for damage in transit. BRYMEN will, at its option, repair or replace the defective product free of charge. However, if BRYMEN determines that the failure was caused by misused, altered, neglected, or damaged by accident or abnormal conditions of operation or handling, you will be billed for the repair.

THIS WARRANTY IS EXCLUSIVE AND IS IN LIEU OF ALL OTHER WARRANTIES, EXPRESSED OR IMPLIED, INCLUDING BUT NOT LIMITED TO ANY IMPLIED WARRANTY OR MERCHANTABILITY OR FITNESS FOR A PARTICULAR PURPOSE OR USE. BRYMEN WILL NOT BE LIABLE FOR ANY SPECIAL, INDIRECT, INCIDENTAL OR CONSEQUENTIAL DAMAGES.



BRYMEN TECHNOLOGY CORPORATION

TEL:+886 2 2226 3396

FAX:+886 2 2225 0025

<http://www.brymen.com>



PRINTED ON RECYCLABLE PAPER, PLEASE RECYCLE

COPYRIGHT © MMVI Btc,

ALL RIGHTS RESERVED

P/N: 7M1C-0901-0000

PRINTED IN TAIWAN