

USER'S MANUAL

BM151, BM152, BM155, &
BM351

PowerClamp™ Series



1) SAFETY

This manual contains information and warnings that must be followed for operating the instrument safely and maintaining the instrument in a safe operating condition. If the instrument is used in a manner not specified by the manufacturer, the protection provided by the instrument may be impaired.

The meter protection rating, against the users, is double insulation per IEC61010-1 2nd Ed., EN61010-1 2nd Ed., UL61010-1 2nd Ed., CAN/CSA C22.2 No. 61010.1-0.92, IEC61010-2-032, EN61010-2-032, UL61010B-2-032, & CAN/CSA C22.2 No. 61010-2-032-04:

Measurement Category III 600V AC & DC.

Per IEC61010-1 2nd Ed. (2001) Measurement Category

Measurement Category IV (CAT IV) is for measurements performed at the source of the low-voltage installation. Examples are electricity meters and measurements on primary overcurrent protection devices and ripple control units.

Measurement Category III (CAT III) is for measurements performed in the building installation. Examples are measurements on distribution boards, circuit-breakers, wiring, including cables, bus-bars, junction boxes, switches, socket-outlets in the fixed installation, and equipment for industrial use and some other equipment, for example, stationary motors with permanent connection to the fixed installation.

Measurement Category II (CAT II) is for measurements performed on circuits directly connected to the low voltage installation. Examples are measurements on household appliances, portable tools and similar equipment.

TERMS IN THIS MANUAL

WARNING identifies conditions and actions that could result in serious injury or even death to the user.

CAUTION identifies conditions and actions that could cause damage or malfunction in the instrument.

WARNING

To reduce the risk of fire or electric shock, do not expose this product to rain or moisture. The meter is intended only for indoor use.

To avoid electrical shock hazard, observe the proper safety precautions when working with voltages above 60 VDC or 30 VAC rms. These voltage levels pose a potential shock hazard to the user.









Keep your hands/fingers behind the hand/finger barriers (of the meter and the test leads) that indicate the limits of safe access of the hand-held part during measurement. Inspect test leads, connectors, and probes for damaged insulation or exposed metal before using the instrument. If any defects are found, replace them immediately.

This Clamp-on meter is designed to apply around or remove from uninsulated hazardous live conductors. But still, individual protective equipment must be used if hazardous live parts in the installation where measurement is to be carried out could be accessible.

CAUTION

Disconnect the test leads from the test points before changing meter functions.

INTERNATIONAL ELECTRICAL SYMBOLS

	Caution ! Refer to the explanation in this Manual
	Caution ! Risk of electric shock
	Earth (Ground)
	Double Insulation or Reinforced insulation
	Fuse
	AC--Alternating Current
	DC--Direct Current
	Application around and removal from hazardous live conductors is permitted

2) CENELEC Directives

The instruments conform to CENELEC Low-voltage directive 2006/95/EC and Electromagnetic compatibility directive 2004/108/EC

3) PRODUCT DESCRIPTION

Note: Top of the line model is used as representative for illustration purposes. Please refer to your respective model for function availability.

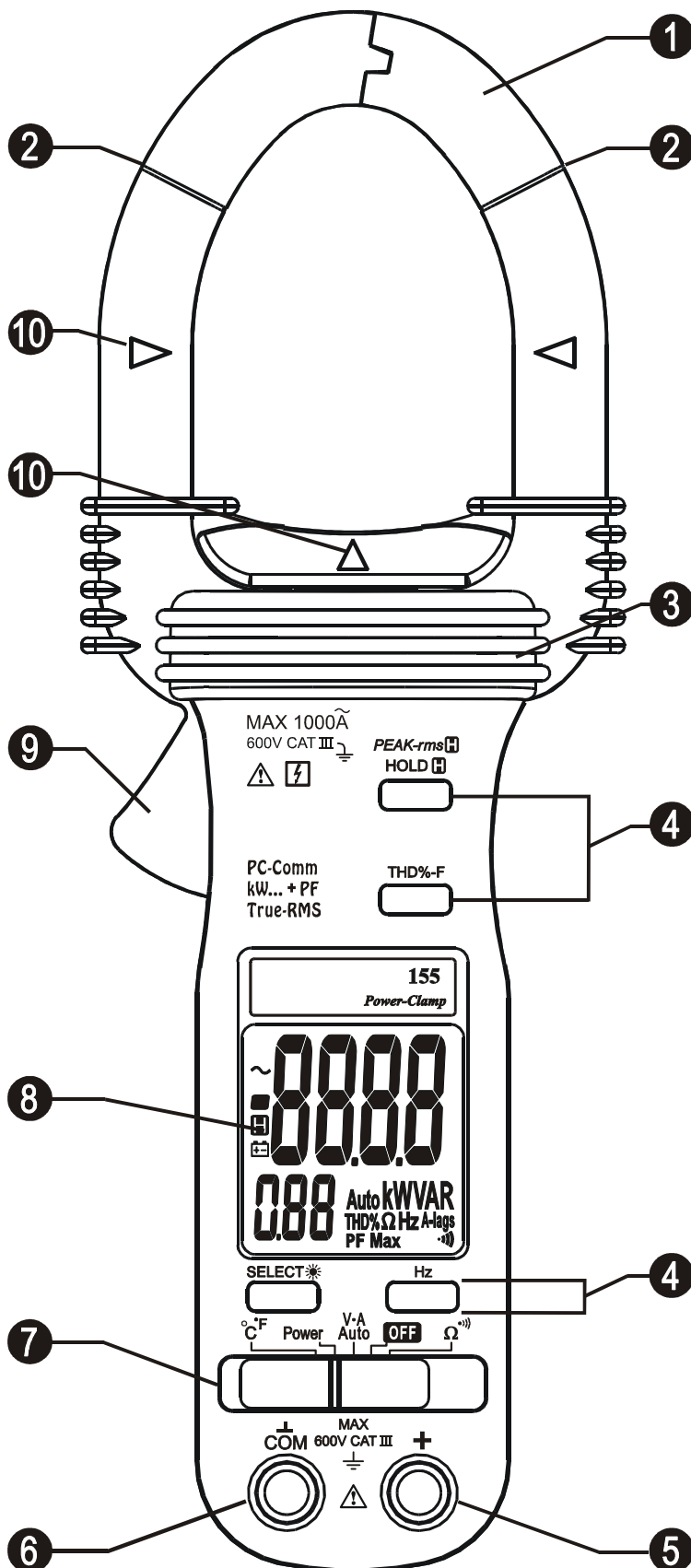

1) Transformer Clamp Jaws for AC current magnetic field pick up

2) Jaw marking lines for ACA (& thus Power) position error indication

3) Hand/Finger Barrier to indicate the limits of safe access to the jaws during current measurements

4) Push-buttons for special functions & features

5) Input Jack for all functions EXCEPT non-invasive ACA current (& thus Power) function

6) Common (Ground reference) Input Jack for all functions EXCEPT non-invasive ACA current (& thus Power) function

7) Slide-switch Selector to turn the power ON/OFF and Select a function

8) LCD display

9) Jaw trigger for opening the transformer clamp jaws

10) Jaw center Indicators, at where best ACA (& thus Power) accuracy is specified

4) OPERATION

CAUTION: Before and after hazardous voltage measurements, test the voltage function on a known source such as line voltage to determine proper meter functioning.

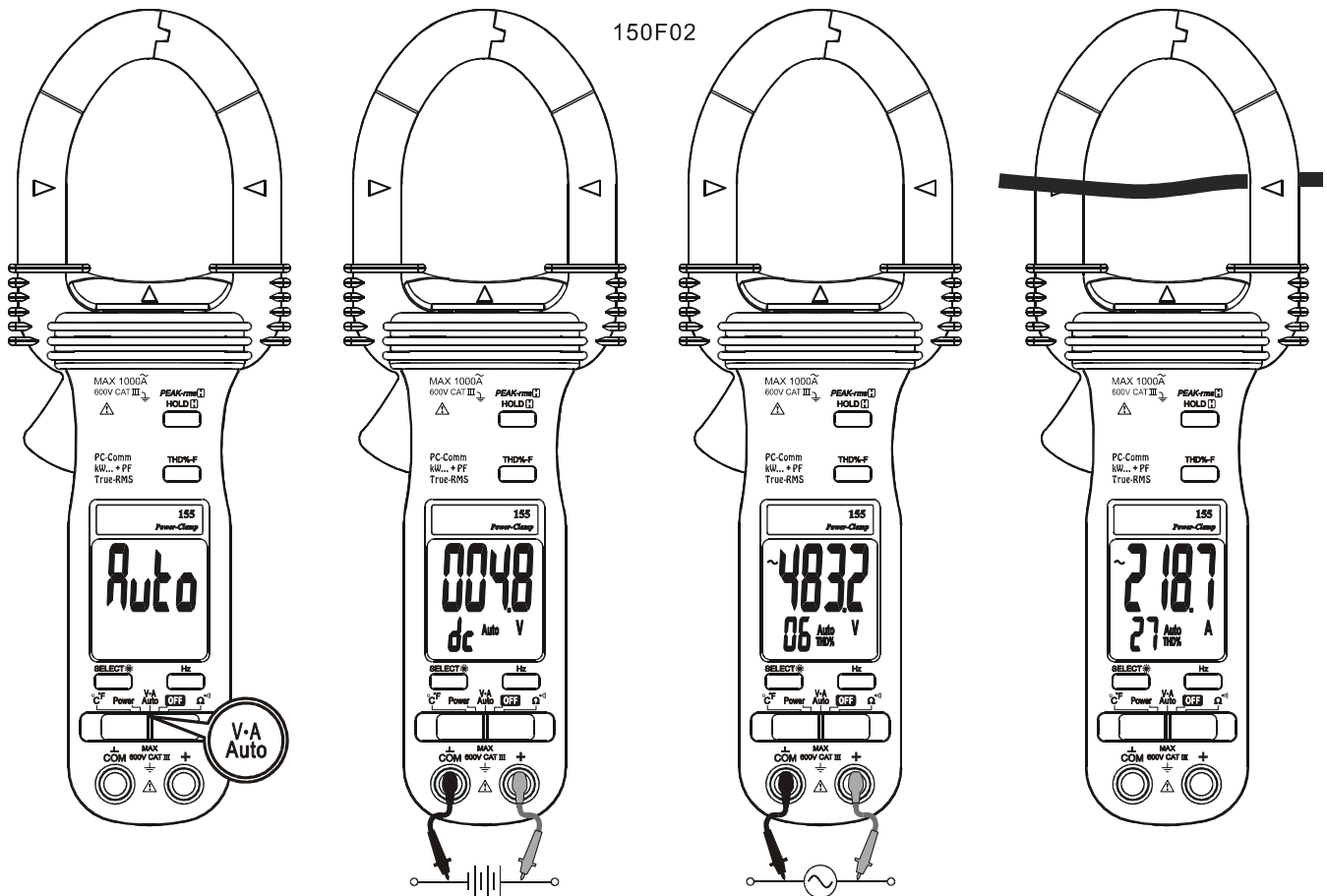

AutoVA™ function

Set the slide-switch function-selector to the ^{V-A} Auto position.

- With no input, the meter displays “Auto” when it is ready.
- With no ACA current input via the jaws but a voltage signal above the nominal threshold of DC 2.4V or AC 30V (40Hz ~ 500Hz) up to the rated 600V is present on V-COM terminals, the meter displays the voltage value in appropriate DC or AC, whichever larger in peak magnitude. LCD annunciator “dc” or “~” turns on respectively.
- On the contrary, with no voltage signal present on V-COM terminals but a ACA current signal above the nominal threshold of AC 1A (40Hz ~ 500Hz) up to the rated 1000A is input via the jaws, the meter displays the ACA current value. LCD annunciator “~” turns on accordingly.
- The Auto-VA feature stays at the auto-selected function as long as its signal remains above the specified threshold. Press **SELECT** button momentarily to manually select thru the functions ACA, ACV, DCV and then goes back to Auto-VA.

CAUTION (Application and removal of the Clamp-on meter)

- For non-invasive ACA current measurements, press the jaw trigger and clamp the

jaws around only one single conductor of a circuit for load current measurement. Make sure the jaws are completely closed, or else it will introduce measurement errors. Enclosing more than one conductor of a circuit will result in differential current measurement (like identifying leakage current). Locate the conductor(s) at the Jaws center as much as possible to get the best measuring accuracy. For removal, press the jaw trigger and remove the jaws from the conductor(s).

● Adjacent current-carrying devices such as transformers, motors and conductor wires will affect measurement accuracy. Keep the jaws away from them as much as possible to minimize influence.

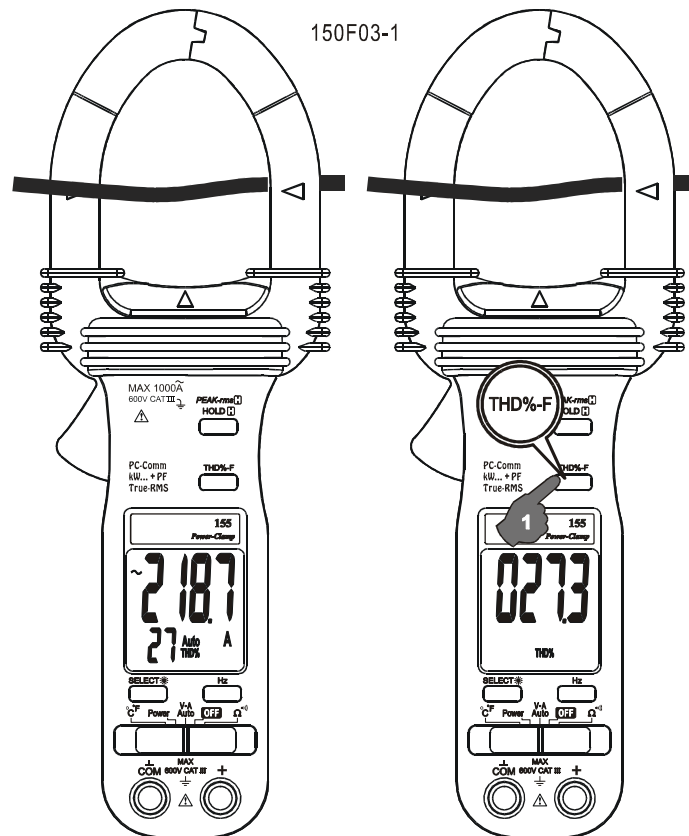

THD%-F Total Harmonic Distortion - Fundamental function (model 155 only)

$$\text{THD}\%-F = (\text{Total Harmonics RMS} / \text{Fundamental RMS}) \times 100\%$$

Total Harmonic Distortion - Fundamental (THD%-F) is the percentage ratio of the Total Harmonics RMS value to the Fundamental RMS value of a voltage or current signal, and is given by the above expression. An ideal sinusoidal waveform has a value of 0 THD%. A badly distorted sinusoidal waveform may have a much higher THD% value of up to several hundreds.

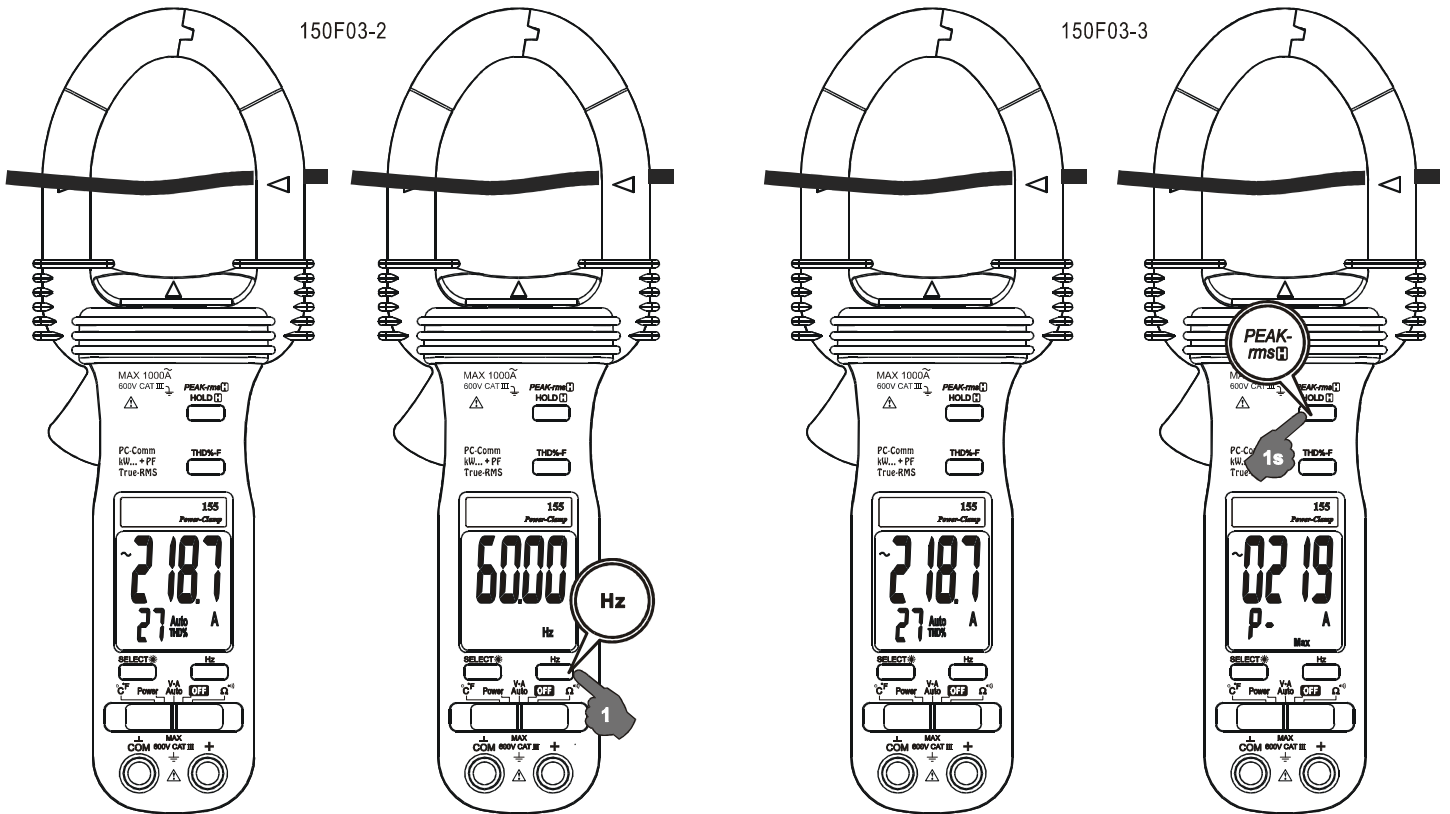

When the meter is in ACV or ACA function, THD%-F values of up to 99 THD% will be displayed in the secondary mini display automatically. Press **THD%-F** button momentarily toggles THD% readings to main display to get full readings of up to 999.9 THD%.





Line-level Frequency function

When ACV or ACA function is auto-selected or manual-selected, press **Hz** button momentarily toggles to Line-level Frequency function. Frequency trigger levels vary automatically with function ranges.



Peak-rms mode

Peak-rms  compares and displays the maximum RMS value of surge voltage or current with durations as short as 65ms. When ACV or ACA function is auto-selected or manual-selected, press and hold **Peak-rms ** button for one second or more toggles to this mode. The LCD annunciators “P-” & “Max” turn on.

Note:

Manually disable the APO feature (press & hold the **HOLD ** button while setting the slide-switch function-selector from any position to the $V \cdot A$ Auto position.) before using **Peak-rms ** mode for long-term measurements.

HOLD mode

Hold mode freezes the display for later viewing. When any function is auto-selected or manual-selected, press **HOLD ** button momentarily toggles to this mode. The annunciator “” turns on.

Notes on Displacement Power Factor & Total Power Factor

● **Introduction:** Power is the rate of change of energy with respect to time (in terms of voltage V and current A). Instantaneous (real) power $w = vi$ where v is the instantaneous voltage and i the instantaneous current. The average (real) power is the mean of vi and is given by:

$$W = \frac{1}{2\pi} \int_0^{2\pi} vi \, dt, \text{ over the interval from } 0 \text{ to } 2\pi / \omega$$

● **Displacement Power Factor (more traditional):** Assuming V and A are pure sinusoidal waveforms without harmonics (as in most traditional cases), that is, $v = V \sin \omega t$ and $i = I \sin(\omega t - \theta)$, the expression can be simplified to:

$W = 1/2 \times V \times I \times \cos \theta$ where V and I are the peak values, θ is the displacement power factor angle, and $\cos \theta$ is the displacement power factor. Using RMS values, it is written as:

$$W = V_{\text{rms}} \times I_{\text{rms}} \times \cos \theta$$

Practically, in such cases without harmonics, θ is also called the phase-shift angle of the current A to the voltage V . An inductive circuit is said to have a lagging power factor since current A lags voltage V (phase-shift angle θ and thus $\sin \theta$ are both "+"), and a capacitive circuit is said to have a leading power factor since current A leads voltage V (phase-shift angle θ and thus $\sin \theta$ are both "-").

● **Total Power Factor (encountering harmonics):** When encountering distorted waveforms with the presence of harmonics, however, the simplified power expression should not be used since substituting the above mentioned pure sinusoidal V and A functions cannot fulfill the actual conditions. *Cosine of phase-shift angle ($\cos \theta$), or the displacement power factor, is no longer the only component constituting the overall power factor. Harmonics do increase apparent power and thus decrease the overall power factor. That is, the Total Power Factor is actually affected by both phase-shift angle and harmonics, and is given by the expression:*

$$\text{Total Power Factor (PF)} = \text{Real Power (W)} / \text{Apparent Power (VA)}$$

In order to improve overall system power factor, nowadays power-system engineer needs to address both phase-shift and harmonics problems. Practically, harmonics should be dealt with (e.g. filtering out) before phase-shift to be corrected (e.g. installing capacitors in parallel with inductive loads).

Power function

Set the slide-switch function-selector to the **Power** position.

● Default at last selected function. Press **SELECT** button momentarily selects between **W** (real power), **VAR** (reactive power) & **VA** (apparent power) measurement functions.

- **PF** (Total Power Factor) displays simultaneously in the secondary mini display. Denoting efficiency, absolute PF value is adopted.
 - **“A-lags”** LCD annunciator turns on to indicate an *inductive* circuit, or *Current A lags Voltage V* (i.e., phase-shift angle θ is “+”).
- On the contrary, together with significant PF values, **WITHOUT** turning on **“A-lags”** indicates a *capacitive* circuit, or *Current A leads Voltage V* (i.e., phase-shift angle θ is “-”).

Note:

1. When measuring load circuits with power absorptions as in most applications, positive W (Real Power) readings indicate correct measurement setups. Negative readings (LCD annunciator “-“ turns on) indicate either the clamp-on jaws direction or the test leads polarity is reversed in such cases. Correct the setups to get proper “A-lags” indications.
2. When encountering largely distorted waveforms, “A-lags” detection might be affected due to the influence of harmonics. As mentioned, it is recommended to deal with (e.g. filter out) harmonics before correcting phase-shift problems.

● **Measuring One or Single Phase Power Parameters:**

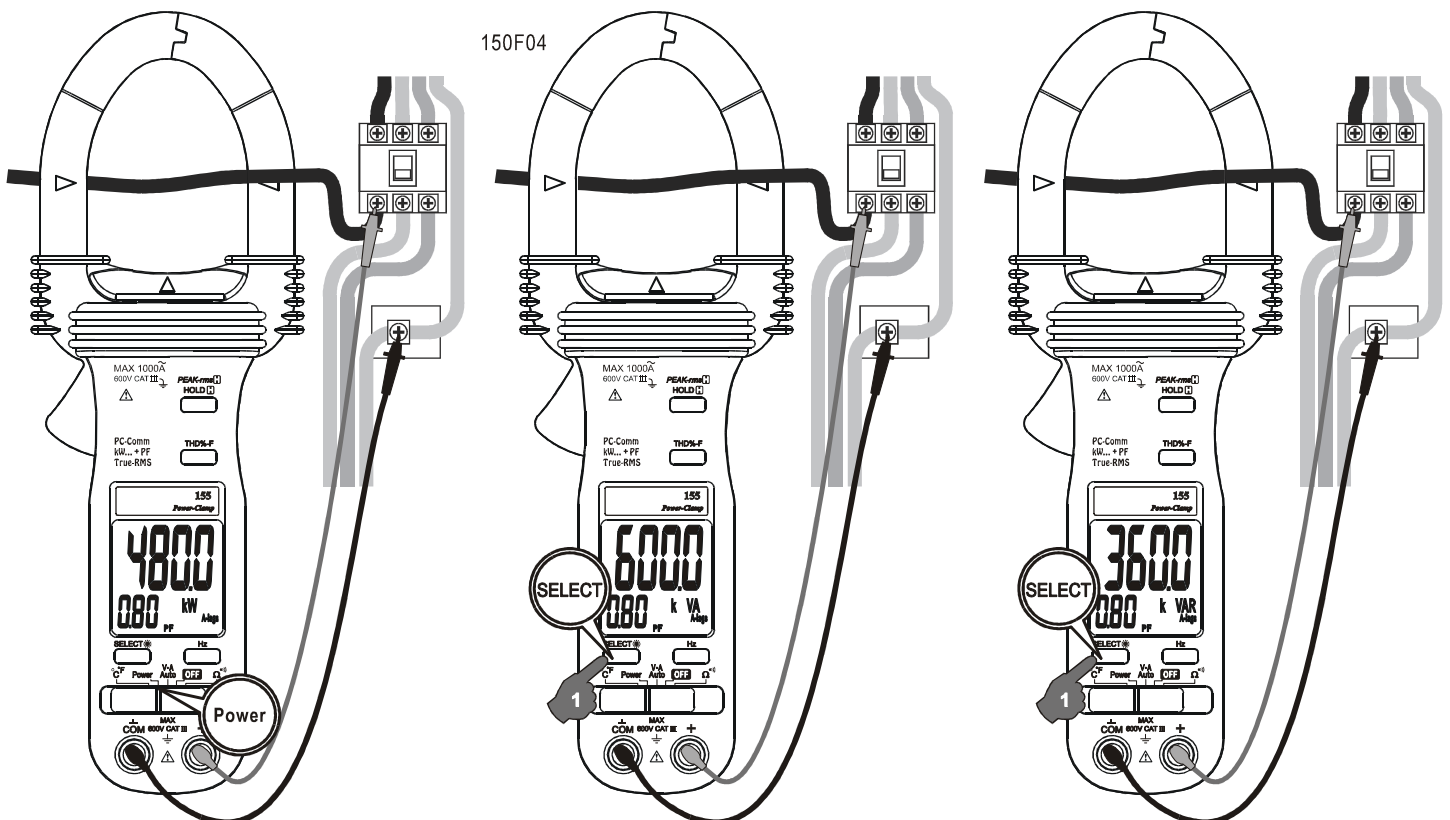

● Measuring 3-Phase 4-Wire (3~4W) Power Parameters:

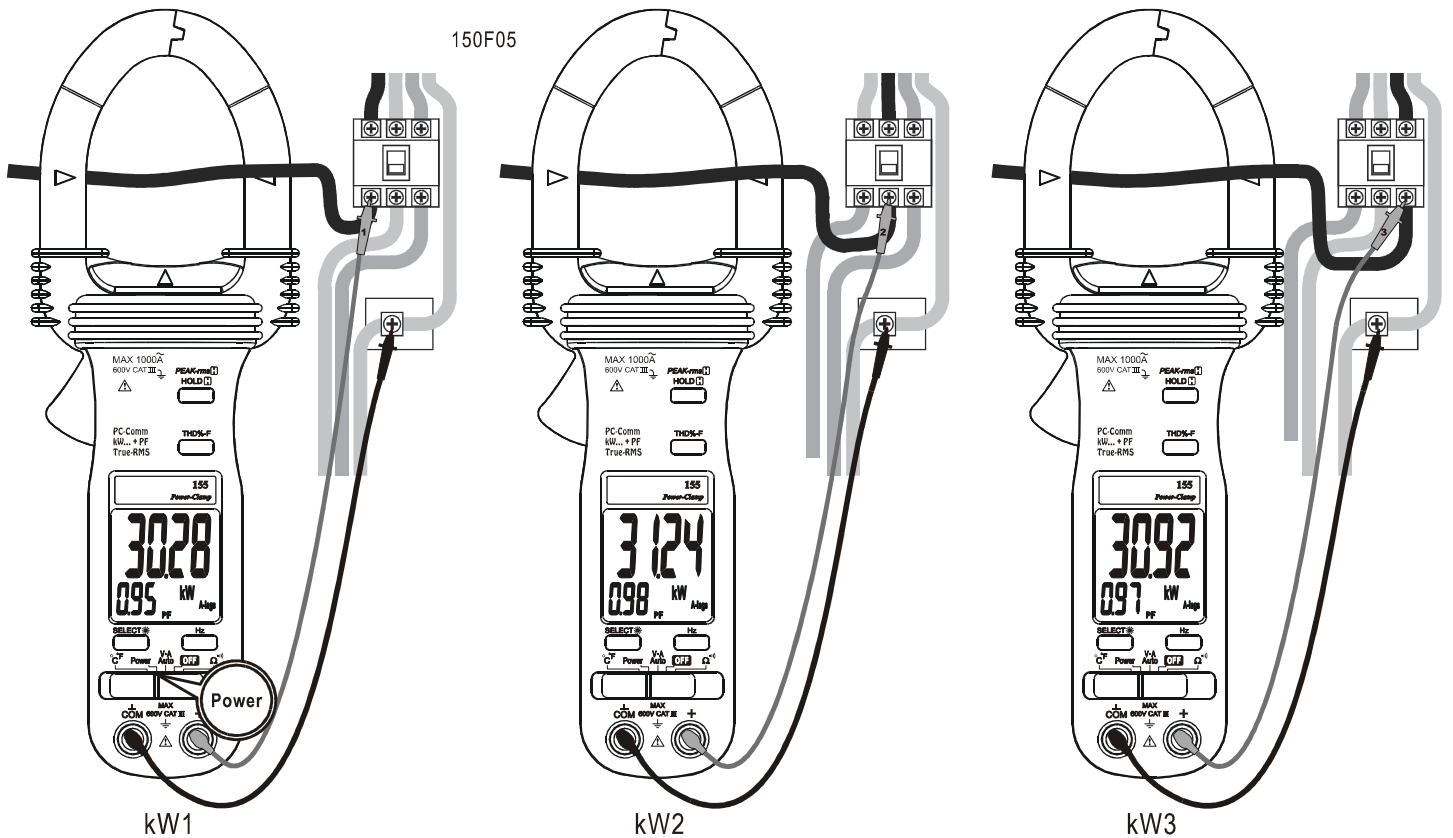

In both un-balanced and balanced load cases, 3-Phase 4-Wire (3~4W) systems, measure the phase-to-neutral powers kW_1 , kW_2 and kW_3 of each phase separately as illustrated. System (total) power kW_{Total} is the summation of all three phase-to-neutral powers. That is:

$$kW_{Total} = kW_1 + kW_2 + kW_3 \quad (\text{for both un-balanced and balanced load cases})$$

In balanced load cases, 3-Phase 4-Wire (3~4W) systems, the system (total) power parameters can be simplified to three times of any of the phase-to-neutral powers. That is:

$$kW_{Total} = 3 \times kW_1 \quad (\text{for balanced load cases only})$$

$$kVA_{Total} = 3 \times kVA_1 \quad (\text{for balanced load cases only})$$

$$kVAR_{Total} = 3 \times kVAR_1 \quad (\text{for balanced load cases only})$$

● Measuring 3-Phase 3-Wire (3~3W) Power Parameters:

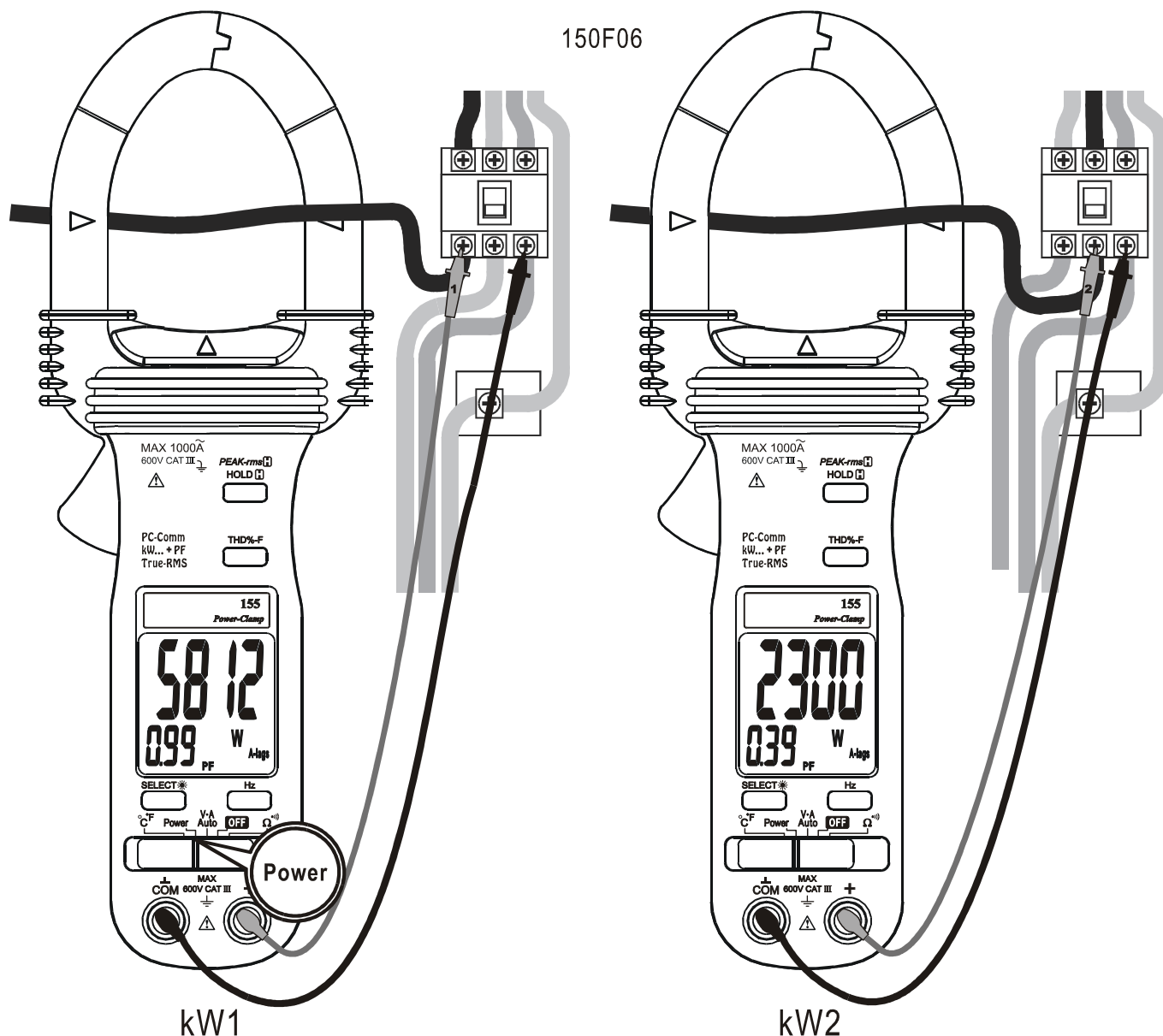

In both un-balanced and balanced load cases, 3-Phase 3-Wire (3~3W) systems, measure the power components kW_1 and kW_2 separately as illustrated. System (total) power kW_{Total} is the summation of the two measured power components. That is:

$$kW_{Total} = kW_1 + kW_2 \text{ (for both un-balanced and balanced load cases)}$$

In balanced load cases, 3-Phase 3-Wire (3~3W) systems, the system (total) power parameters can be achieved by the following expressions:

$$kW_{Total} = kW_1 + kW_2 \quad \text{(same as above)}$$

$$kVA_{Total} = \sqrt{3} \times kVA_1 \quad \text{(for balanced load cases only)}$$

$$kVAR_{Total} = \sqrt{(kVA_{Total}^2 - kW_{Total}^2)} \quad \text{(for balanced load cases only)}$$

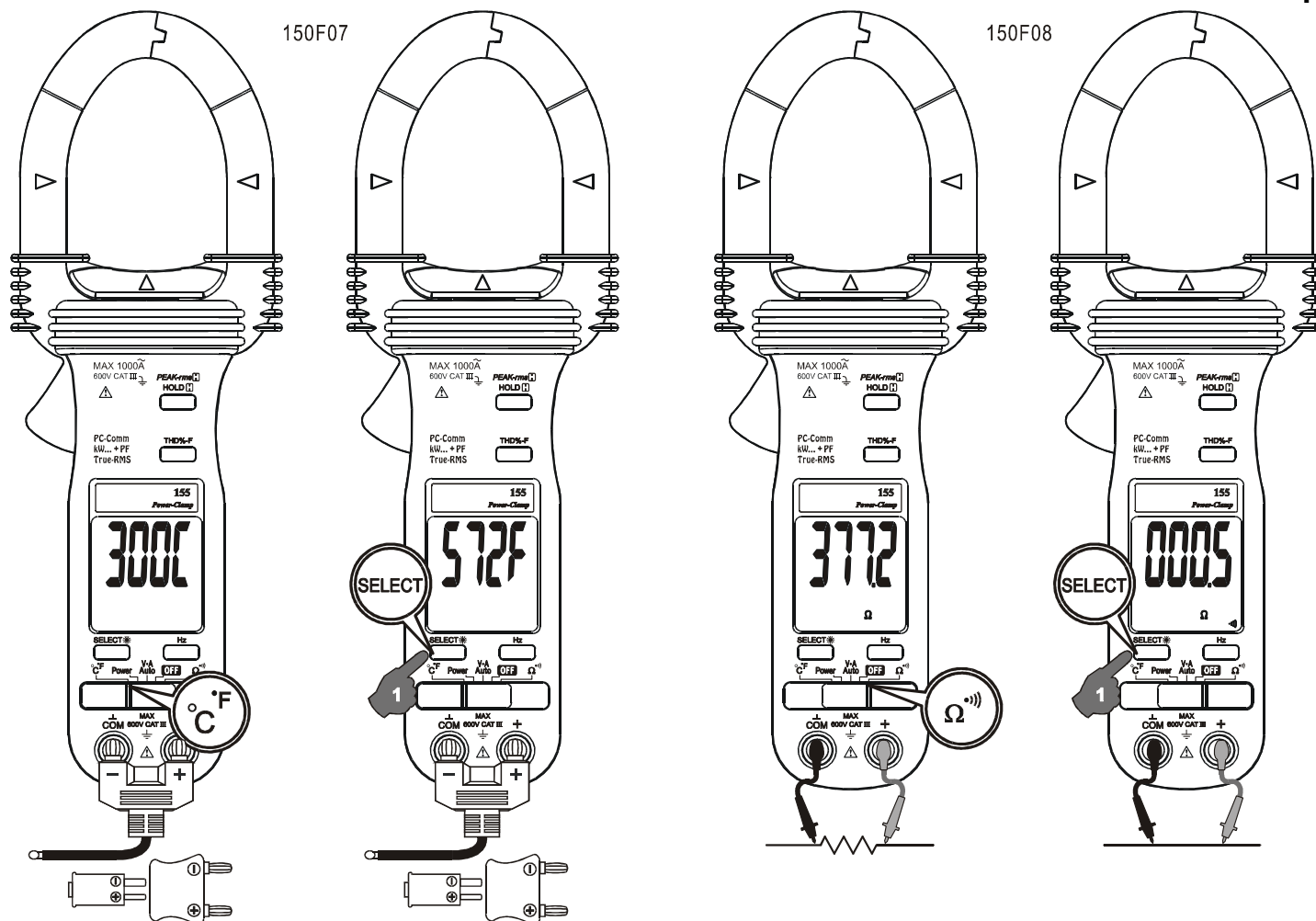

Temperature function (model 152 & 155 only)

Set the slide-switch function-selector to the °C/°F position. Default at last selected function. Press **SELECT** button to toggle between °C and °F measurement functions. Be sure to insert the banana-plug type-K temperature bead probe Bkp60 at correct **+** **-** polarities. You can also use a plug adapter Bkb32 (Optional purchase) with banana pins to type-K socket to adapt other type-K standard mini plug temperature probes.

Ω/•)) functions

Set the slide-switch function-selector to the Ω/•)) function position. Default at last selected function. Press **SELECT** button to toggle between Ω and •)) measurement functions.

Backlight display (models 152 & 155 only)

Press the **SELECT** button for 1 second or more to toggle the display backlight on or off.

Auto Power Off (APO)

The meter turns off after approximately 17 minutes of neither switch nor button activity. To wake up the meter from APO, slide the function-selector to other positions and back on again. Always turn the function-selector to OFF when the meter is not in use.

Disabling Auto-Power-Off (APO)

Press-and-hold the **HOLD** button while sliding the function-selector to a (designated) function-selector position. This disables the Auto-Power-Off feature of the functions on that particular function-selector position. The LCD displays “SLP” & “OFF” to confirm activation right after the **HOLD** button is released. *Slide the function-selector to any other positions will then resume Auto-Power-Off feature.*

PC computer interface capabilities

The instrument equips with an optical isolated data output port at the bottom case near the battery compartment. Optional purchase PC interface kit BRUA-13X (includes BA-1XX Optical Adapter Back, BC-100R Cable, BUA-2303 USB-to-Serial adaptor & Bs software/driver CD) is required to connect the meter to PC computer USB port. The Data Recording System software equips with a digital meter, an analog meter, a comparator meter, and a Data Graphical recorder. Refer to the README file that comes with the interface kit for further details.

Press-and-hold the **Hz** button while sliding the function-selector to a (designated) function-selector position. This enables data output of the functions on that particular function-selector position. The LCD displays “.r” to confirm activation right after the **Hz** button is released. *Slide the function-selector to any other positions will then disable data output.*

5) MAINTENANCE

WARNING

To avoid electrical shock, disconnect the meter from any circuit, remove the test leads from the input jacks and turn OFF the meter before opening the case. Do not operate with open case.

Trouble Shooting

If the instrument fails to operate, check batteries and test leads etc., and replace as necessary. Double check operating procedure as described in this user’s manual

If the instrument voltage-resistance input terminal has subjected to high voltage transient (caused by lightning or switching surge to the system) by accident or abnormal conditions of operation, the series fusible resistors will be blown off (become high impedance) like fuses to protect the user and the instrument. Most measuring functions through this terminal will then be open circuit. The series fusible resistors and the spark gaps should then be replaced by qualified technician. Refer to the LIMITED WARRANTY section for obtaining warranty or repairing service.

Cleaning and Storage

Periodically wipe the case with a damp cloth and mild detergent; do not use abrasives or solvents. If the meter is not to be used for periods of longer than 60 days, remove the batteries and store them separately

Battery replacement

The meter uses standard 1.5V AAA Size (NEDA 24A or IEC LR03) battery X 2
Loosen the 2 captive screws from the battery cover case. Lift the battery cover case. Replace the batteries. Replace battery cover case. Re-fasten the screws.

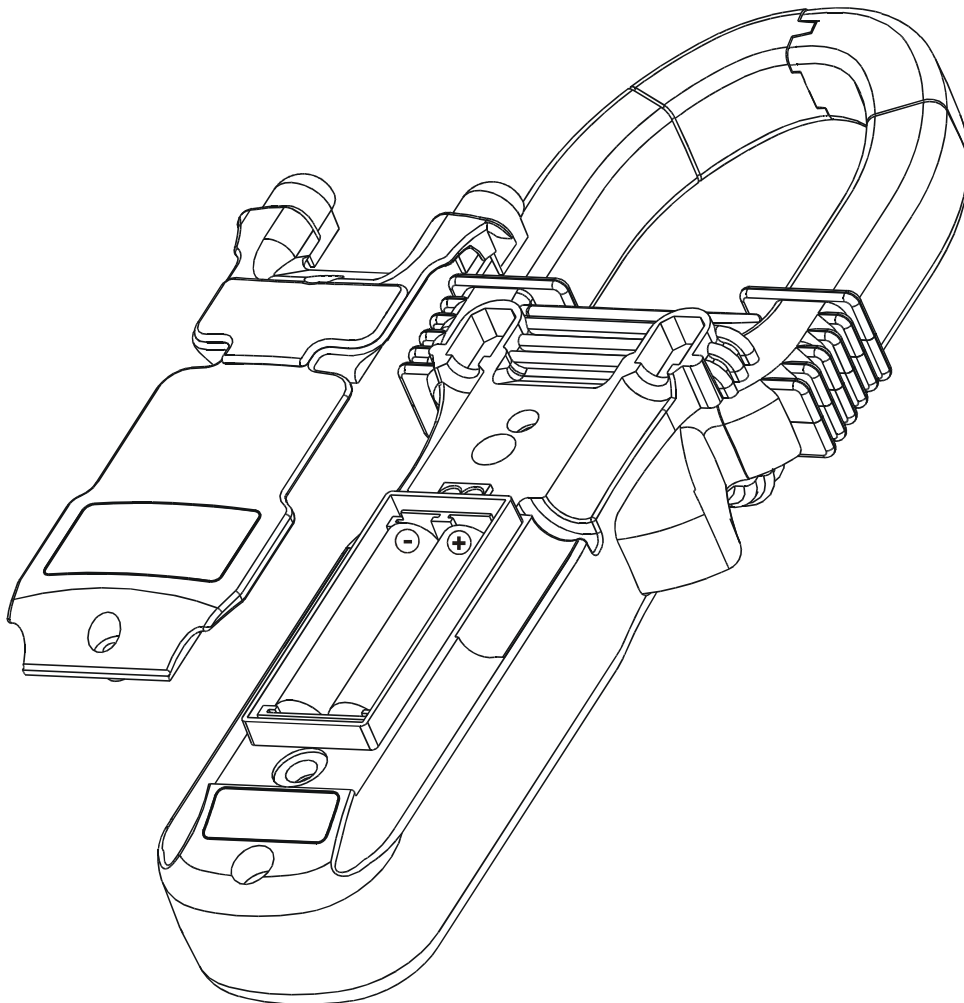

6) Specifications

General Specifications

Display :

Voltage functions: 6000 counts LCD display(s)

Power, Ohm & Hz functions: 9999 counts LCD display(s)

ACA clamp-on function: 4000 counts LCD display(s)

Update Rate :

Power function: 1 per second nominal

Voltage, ACA clamp-on, Ohm, Hz & Temperature functions: 4 per second nominal

Polarity : Automatic

Low Battery : Below approx. 2.4V

Operating Temperature : 0°C to 40°C

Relative Humidity : Maximum relative humidity 80% for temperature up to 31°C decreasing linearly to 50% relative humidity at 40°C

Altitude : Operating below 2000m

Storage Temperature : -20°C to 60°C, < 80% R.H. (with battery removed)

Temperature Coefficient : nominal 0.15 x (specified accuracy)/ °C @ (0°C -18°C or 28°C -40°C), or otherwise specified

Sensing : True RMS sensing for all models

Safety : Meets IEC61010-1 2nd Ed., EN61010-1 2nd Ed., UL61010-1 2nd Ed., CAN/CSA C22.2 No. 61010.1-0.92, IEC61010-2-032, EN61010-2-032, UL61010B-2-032, & CAN/CSA C22.2 No. 61010-2-032-04:

Measurement Category : III 600 Volts ac & dc

Transient protection : 6.5kV (1.2/50µs surge) for all models

Pollution degree : 2

E.M.C. : Meets EN61326-1:2006 (EN55022, EN61000-3-2, EN61000-3-3, EN61000-4-2, EN61000-4-3, EN61000-4-4, , EN61000-4-5, EN61000-4-6, EN61000-4-8, EN61000-4-11)

In an RF field of 3V/m:

Total Accuracy = Specified Accuracy + 45 digits

Performance above 3V/m is not specified

Overload Protections :

ACA Clamp-on jaws :

AC 1000A rms continuous for model 151, 152 & 155

AC 600A rms continuous for model 351

+ & COM terminals (all functions) : 600VDC/VAC rms

Power Supply : standard 1.5V AAA Size (NEDA 24A or IEC LR03) battery X 2

Power Consumption :

Voltage, ACA, Hz & Power functions: 10mA typical

Ohm & Temperature functions: 4mA typical

APO Timing : Idle for 17 minutes

APO Consumption : 10µA typical

Dimension : L224mm X W78mm X H40mm for model 151, 152 & 155; L189 X W78 X H40 mm for model 351

Weight : 224 gm approx for model 151, 152 & 155; 192 gm approx for model 351

Jaw opening & Conductor diameter : 45mm max for model 151, 152 & 155; 26mm max for model 351

Special features : Backlight display (model 152 & 155 only); AutoVA™ (Auto Selection on ACV, DCV or ACA functions); Power measurement of selectable W, VAR & VA with dual-display Total Power Factor features; Total harmonic distortion THD%-F (model 155 only); PEAK-rms HOLD

Accessories : Test leads (pair), batteries installed, user's manual, soft carrying pouch, & BKP60 banana plug type-K thermocouple (model 152 & 155 only)

Optional accessories : PC interface kit BRUA-13X (including BA-1XX Optical Adapter Back, BC-100R Cable, BUA-2303 USB-to-Serial adaptor & Bs software/driver CD), BKB32 banana plug to type-K socket plug adaptor (model 152 & 155 only)

Electrical Specifications

Accuracy is \pm (% reading digits + number of digits) or otherwise specified, at 23 °C \pm 5 °C & less than 75% R.H.

True RMS (all models) ACV & ACA clamp-on accuracies are specified from 0% to 100% of range or otherwise specified. Maximum Crest Factor are as specified below, and with frequency spectrums, besides fundamentals, fall within the meter specified AC bandwidth for non-sinusoidal waveforms. Fundamentals are specified at 50Hz and 60Hz.

AC Voltage

RANGE	Accuracy
50Hz / 60Hz	
600.0V	0.5% + 5d
45Hz ~ 500Hz	
600.0V	1.5% + 5d
500Hz ~ 3.1kHz	
600.0V	2.5% + 5d

Input Impedance: 2M Ω , 30pF nominal

Crest Factor:

model 151, 152, 155 & 351: < 2 : 1 at full scale & < 4 : 1 at half scale

ACV AutoVA™ Threshold: 30VAC (40Hz ~ 500Hz only) nominal

PEAK-rms HOLD (ACA & ACV only)

Response: 65ms to 90%

DC Voltage

RANGE	Accuracy
600.0V	0.5% + 5d

Input Impedance: 2M Ω , 30pF nominal

DCV AutoVA™ Threshold: 2.4VDC nominal

Ohms

RANGE	Accuracy
999.9 Ω	1.0% + 6d

Open Circuit Voltage : 0.4VDC typical

Audible Continuity Tester

Audible threshold: between 10 Ω and 300 Ω .

Response time: 250 μ s

ACA Current (Clamp-on)

RANGE	Accuracy ^{1) 2)}
50Hz / 60Hz	
40.00A, 400.0A, 1000A (600A for model 351)	1.0% + 5d
45Hz ~500Hz	
40.00A, 400.0A	2.0% + 5d
1000A (600A for model 351)	2.5% + 5d
500Hz ~ 3.1kHz	
40.00A, 400.0A	2.5% + 5d
1000A (600A for model 351)	3.0% + 5d

ACA AutoVA™ Threshold: 1A AC (40Hz ~ 500Hz only) nominal

Crest Factor:

model 151, 152 & 155:

< 2.1 : 1 at full scale & < 4.2 : 1 at half scale for 40.00A & 400.0A ranges

< 1.6 : 1 at full scale & < 3.2 : 1 at half scale for 1000A range

model 351:

< 2.5 : 1 at full scale & < 5 : 1 at half scale for 40.00A & 400.0A ranges

< 3 : 1 at full scale & < 6 : 1 at half scale for 600A ranges

¹⁾Induced error from adjacent current-carrying conductor: < 0.06A/A

²⁾Specified accuracy is from 1% to 100% of range and for measurements made at the jaw center. When the conductor is not positioned at the jaw center, position

errors introduced are:

Add 1% to specified accuracy for measurements made WITHIN jaw marking lines (away from jaw opening)

Add 4% to specified accuracy for measurements made BEYOND jaw marking lines (toward jaws opening)

Temperature (model 152 & 155 only)

RANGE	Accuracy
-50°C ~ 300°C	2.0% + 3°C
-58°F ~ 572°F	2.0% + 6°F

Type-K thermocouple range & accuracy not included

Add 3°C (or 6°F) to specified accuracy @ -20°C ~ -50°C (or @ -4°F ~ -58°F)

Frequency

RANGE	Accuracy
5.00Hz ~ 500.0Hz	0.5%+4d

Sensitivity (Sine RMS)

40A range: > 4A

400A range: > 40A

1000A (600A for model 351) range: > 400A

600V range: > 30V

THD%-F ¹⁾ (model 155 only)

RANGE	Harmonic order	Accuracy ^{3) 4)}
0.0% ~100.0% ²⁾	Fundamental	1.5% of Reading + 6d
	2nd ~ 3rd	5.0% of Reading + 6d
	4th ~ 16th	2.5% of Reading + 6d
	17th ~ 41st	3.0% of Reading + 6d
	41st ~ 51st	4.5% of Reading + 6d ⁵⁾

¹⁾THD-F is defined as:

$(\text{Total Harmonic RMS} / \text{Fundamental RMS}) \times 100\%$

²⁾Range & resolution for Dual Display mode: 0% ~ 99%

³⁾Specified accuracy @ ACA fundamental > 5A ; ACV fundamental > 50V

⁴⁾Add 6d to specified accuracy @ THD-F readings < 10% or > 75%

⁵⁾Unspecified @ THD-F readings > 95%

Total Power Factor (PF)

RANGE	Accuracy ¹⁾	
	0.10 ~ 0.99	F ~ 21st 3d

¹⁾Specified accuracy @ ACA fundamental > 2A ; ACV fundamental > 50V

Power

RANGE 0 ~ 600.0 ⁴⁾ kVA @ PF = 0.99 ~ 0.1	Accuracy ^{1) 2)}		
		F ~ 10th 2.0%+6d	11th ~ 46th 3.5%+6d

RANGE 0 ~ 600.0 ⁴⁾ kW / kVAR @ PF = 0.99 ~ 0.70 @ PF = 0.70 ~ 0.50 @ PF = 0.50 ~ 0.30 @ PF = 0.30 ~ 0.20	Accuracy ^{1) 3)}			
		F ~ 10th	11th ~ 25th	26th ~ 46th
	2.0%+6d	3.5%+6d	4.5%+6d	10%+6d
	3.0%+6d			
	4.5%+6d			
	10%+6d		15%+6d	

¹⁾Specified accuracy is for ACA clamp measurement at the center of jaws. When the conductor is not positioned at the jaw center, position errors introduced are:

Add 1% to specified accuracy for ACA measurements made WITHIN jaw marking lines (away from jaw opening)

Accuracy is not specified for ACA measurement made BEYOND jaw marking lines (toward jaws opening)

²⁾Add 1% to specified accuracy @ ACA fundamental < 6A or ACV fundamental < 90V. Accuracy is not specified @ ACA fundamental < 1A or ACV fundamental < 30V

³⁾Add 1% to specified accuracy @ ACA fundamental < 6A or ACV fundamental < 90V. Accuracy is not specified @ ACA fundamental < 2A or ACV fundamental < 50V

⁴⁾0 ~ 360.0 for model 351

A-lags ¹⁾ Indication:

“A-lags” LCD annunciator turns on to indicate an inductive circuit, or Current A lags Voltage V (i.e., phase-shift angle θ is “+”).

¹⁾A-lags Indication is specified at 50/60Hz fundamental without harmonics, and at ACV > 90V, ACA > 9A, & PF < 0.95

LIMITED WARRANTY

BRYMEN warrants to the original product purchaser that each product it manufactures will be free from defects in material and workmanship under normal use and service within a period of one year from the date of purchase. BRYMEN's warranty does not apply to accessories, fuses, fusible resistors, spark gaps, batteries or any product which, in BRYMEN's opinion, has been misused, altered, neglected, or damaged by accident or abnormal conditions of operation or handling.

To obtain warranty service, contact your nearest BRYMEN authorized agent or send the product, with proof of purchase and description of the difficulty, postage and insurance prepaid, to BRYMEN TECHNOLOGY CORPORATION. BRYMEN assumes no risk for damage in transit. BRYMEN will, at its option, repair or replace the defective product free of charge. However, if BRYMEN determines that the failure was caused by misused, altered, neglected, or damaged by accident or abnormal conditions of operation or handling, you will be billed for the repair.

THIS WARRANTY IS EXCLUSIVE AND IS IN LIEU OF ALL OTHER WARRANTIES, EXPRESSED OR IMPLIED, INCLUDING BUT NOT LIMITED TO ANY IMPLIED WARRANTY OR MERCHANTABILITY OR FITNESS FOR A PARTICULAR PURPOSE OR USE. BRYMEN WILL NOT BE LIABLE FOR ANY SPECIAL, INDIRECT, INCIDENTAL OR CONSEQUENTIAL DAMAGES.



BRYMEN TECHNOLOGY CORPORATION

TEL:+886 2 2226 3396

FAX:+886 2 2225 0025

<http://www.brymen.com>



PRINTED ON RECYCLABLE PAPER, PLEASE RECYCLE
COPYRIGHT © MMX Btc, ALL RIGHTS RESERVED
P/N:7M1C-1111-0000 PRINTED IN TAIWAN