

USER'S MANUAL

BM117/BM118 Auto-Check™ Clamp-on Multimeter Series



1) SAFETY

This manual contains information and warnings that must be followed for operating the instrument safely and maintaining the instrument in a safe operating condition. If the instrument is used in a manner not specified by the manufacturer, the protection provided by the instrument may be impaired.

The meter meets the requirements for double insulation to IEC61010-2-032(2002), EN61010-2-032(2002), UL61010B-2-032(2003):

Category III 600 Volts ac and dc.

PER IEC61010 OVERVOLTAGE INSTALLATION CATEGORY

OVERVOLTAGE CATEGORY II

Equipment of OVERVOLTAGE CATEGORY II is energy-consuming equipment to be supplied from the fixed installation.

Note – Examples include household, office, and laboratory appliances.

OVERVOLTAGE CATEGORY III

Equipment of OVERVOLTAGE CATEGORY III is equipment in fixed installations.

Note – Examples include switches in the fixed installation and some equipment for industrial use with permanent connection to the fixed installation.

OVERVOLTAGE CATEGORY IV

Equipment of OVERVOLTAGE CATEGORY IV is for use at the origin of the installation. Note – Examples include electricity meters and primary over-current protection equipment.

TERMS IN THIS MANUAL

WARNING identifies conditions and actions that could result in serious injury or even death to the user.

CAUTION identifies conditions and actions that could cause damage or malfunction in the instrument.

WARNING

To reduce the risk of fire or electric shock, do not expose this product to rain or moisture. The meter is intended only for indoor use.

To avoid electrical shock hazard, observe the proper safety precautions when working with voltages above 60 VDC or 30 VAC rms. These voltage levels pose a potential shock hazard to the user.









Keep your hands/fingers behind the hand/finger barriers (of the meter and the test leads) that indicate the limits of safe access of the hand-held part during measurement. Inspect test leads, connectors, and probes for damaged insulation or exposed metal before using the instrument. If any defects are found, replace them immediately.

This Clamp-on meter is designed to apply around or remove from uninsulated hazardous live conductors. But still, individual protective equipment must be used if hazardous live parts in the installation where measurement is to be carried out could be accessible.

CAUTION

Disconnect the test leads from the test points before changing meter functions.

INTERNATIONAL ELECTRICAL SYMBOLS

	Caution ! Refer to the explanation in this Manual
	Caution ! Risk of electric shock
	Earth (Ground)
	Double Insulation or Reinforced insulation
	Fuse
	AC--Alternating Current
	DC--Direct Current
	Application around and removal from hazardous live conductors is permitted

2) CENELEC Directives

The instruments conform to CENELEC Low-voltage directive 73/23/EEC and Electromagnetic compatibility directive 89/336/EEC

3) PRODUCT DESCRIPTION

This user's manual uses only representative model(s) for illustrations. Please refer specification details for function availability to each model.

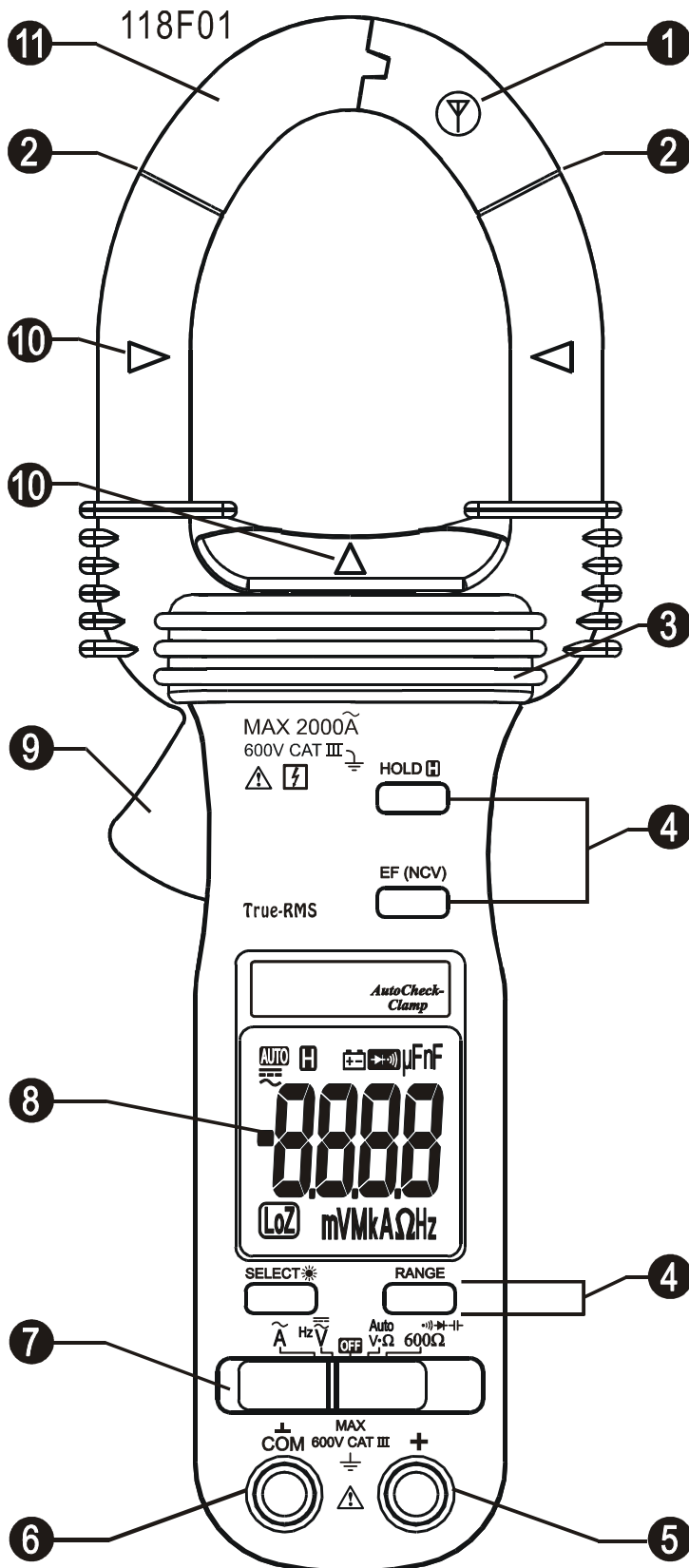

- 1) Non-Contact EF-Detection (NCV): antenna position
- 2) Jaw marking lines for ACA position error indication
- 3) Hand/Finger Barrier to indicate the limits of safe access to the jaws during current measurements
- 4) Push-buttons for special functions & features
- 5) Input Jack for all functions EXCEPT non-invasive ACA current function
- 6) Common (Ground reference) Input Jack for all functions EXCEPT non-invasive ACA current function
- 7) Slide-switch Selector to turn the power ON/OFF and Select a function
- 8) 3-5/6 digits 6000 counts LCD display
- 9) Jaw trigger for opening the transformer clamp jaws
- 10) Jaw center Indicators, at where best ACA accuracy is specified
- 11) Transformer Clamp Jaws for AC current magnetic field pick up

4) OPERATION

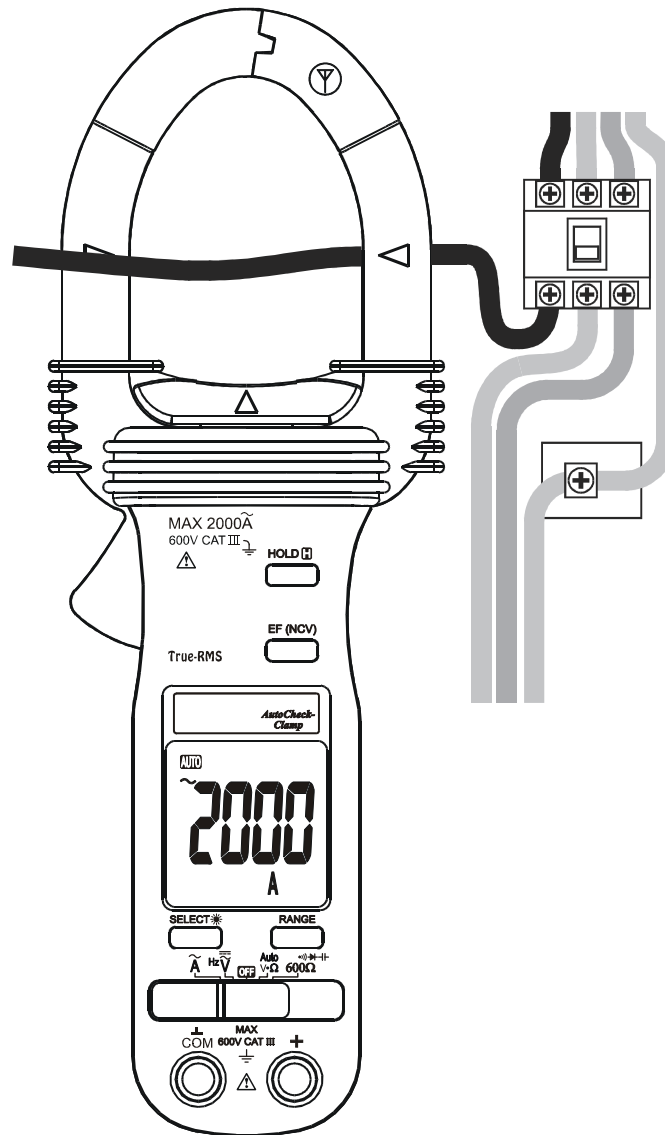

ACA Current clamp-on function

Set the slide-switch function selector to the \tilde{A} position. Inputs are made through the clamp jaws for non-invasive ACA current measurements.

CAUTION (Application and removal of the Clamp-on meter)

- Press the jaw trigger and clamp the jaws around only one single conductor of a circuit for load current measurement. Make sure the jaws are completely closed, or else it will introduce measurement errors. Enclosing more than one conductor of a circuit will result in differential current (like identifying leakage current) measurement. Locate the conductor(s) at the Jaws center as much as possible to get the best measuring accuracy. For removal, press the jaw trigger and remove the jaws from the conductor(s).

- Adjacent current-carrying devices such as transformers, motors and conductor wires will affect measurement accuracy. Keep the jaws away from them as much as possible to minimize influence.

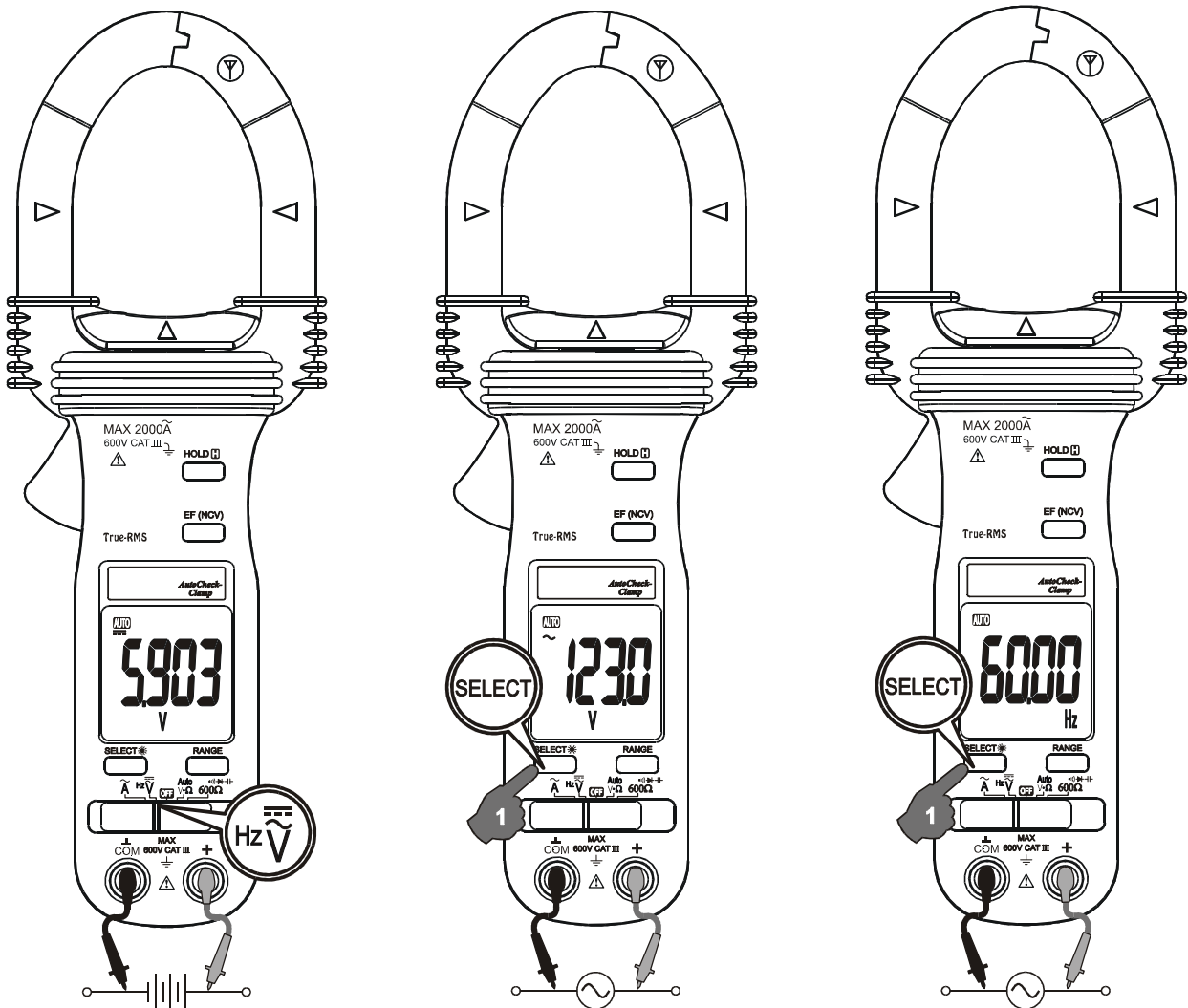

Hi-Z DCV, ACV & Line-Level Hz functions

Set the slide-switch function selector to the $\text{Hz} \overline{\text{V}}$ position selects common impedance (Hi-Z) voltage measurements. Input impedance is set at approximately $5\text{M}\Omega$ to minimize loading on circuits under tests. DCV is the default function. The DC annunciator “ $\overline{\text{V}}$ ” turns on. Press **SELECT** button momentarily to select ACV. The AC annunciator “ \sim ” turns on. Press momentarily again to activate the Line-Level Hz function.

Note:

● *Line-Level Hz input sensitivity varies automatically with ACV range selected when Line-Level Hz is selected. AC 6V range has the highest and AC 600V range has the lowest sensitivity. Measuring the signal in ACV function WHILE selecting Line-Level Hz function in that ACV range automatically sets the most appropriate sensitivity for higher voltage applications. This can avoid electrical noises as in 110/220V line voltage applications for example. If the reading shows zero due to insufficient signal levels, select Line-Level Hz function BEFORE making measurements (at AC 6V range) will set the highest sensitivity.*

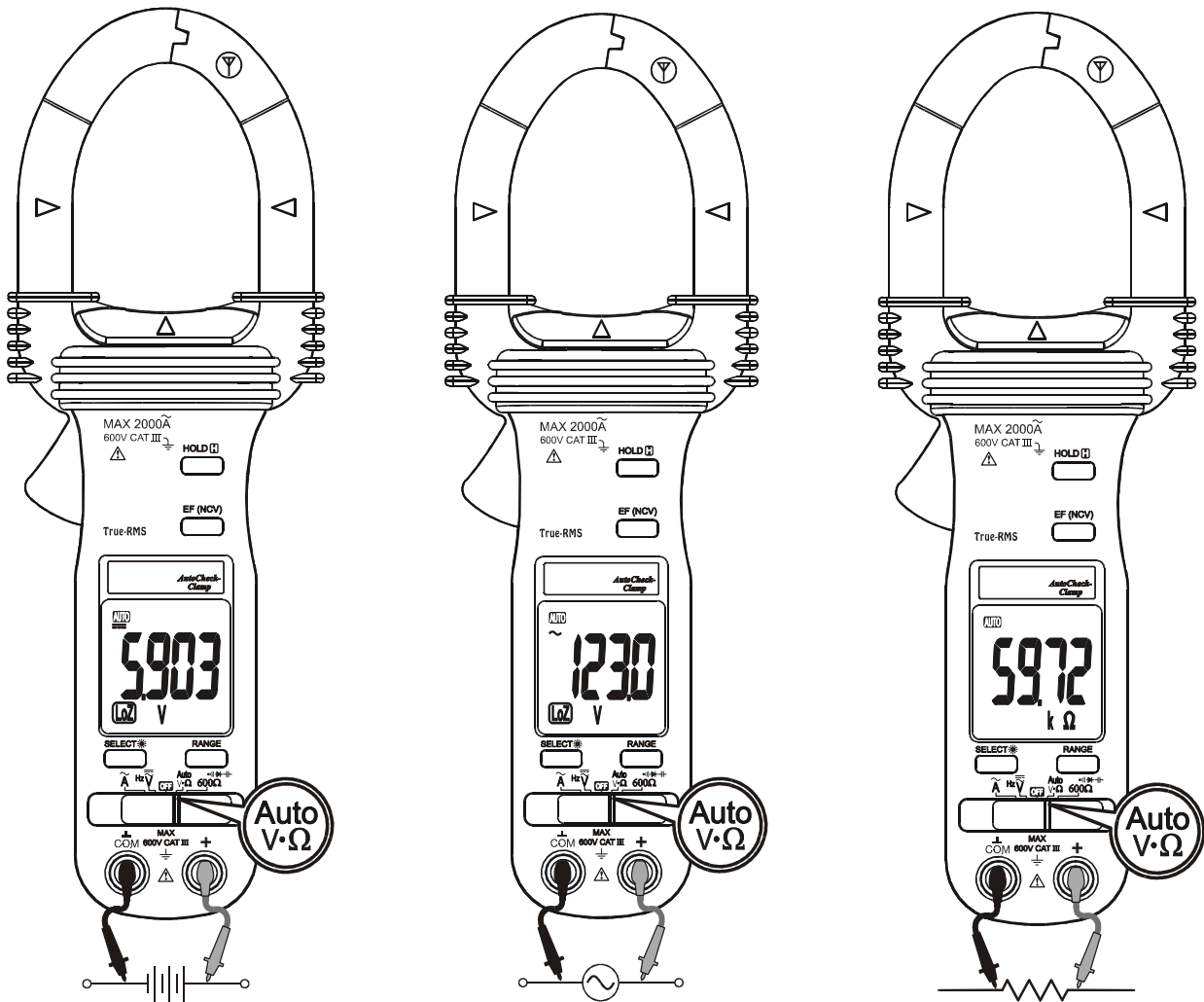

AutoCheck™ mode

Set the slide-switch function selector to the $\overset{\text{Auto}}{V \cdot \Omega}$ position. This innovative AutoCheck™ feature automatically selects measurement function of DCV, ACV or Resistance (Ω) based on the input via the test leads.

- With no input, the meter displays “Auto” when it is ready.
- With no voltage signal but a resistance below $6M\Omega$ is present, the meter displays the resistance value. When below 25Ω ($0.025k\Omega$) is present, the meter further gives a continuity beep tone.
- When a signal above the threshold of +1.5 VDC, -1 VDC or 2 VAC up to the rated 600V is present, the meter displays the voltage value in appropriate DC or AC, whichever larger in peak magnitude.
- **Overload-Alert Feature:** When above rated 600V is present, the meter displays “OL” with a warning beep tone for over-range indication. Disconnect the test leads from the signal immediately to avoid hazards.

Note:

- **Range-Lock Feature:** When a measurement reading is being displayed in

AutoCheck™ mode, press the **RANGE** button momentarily 1 time can lock the function-range it was in. The LCD annunciator “**AUTO**” turns off. Range-lock can speed up repetitive measurements. Press the button momentarily repeatedly to step through the ranges. Press and hold the button for 1 second or more to resume AutoCheck™ mode.

● **As Hazardous-Alert:** When making resistance measurements in AutoCheck™ mode, an unexpected display of voltage readings alerts you that the object under test is being energized.

● **Ghost-voltage buster:** Ghost-voltages are unwanted stray signals coupled from adjacent hard signals, which confuse common multimeter voltage measurements. Our AutoCheck™ mode provides low (ramp-up) input impedance (approx. 1.6kΩ at low voltage) to drain ghost voltages leaving mainly hard signal values on meter readings. It is an invaluable feature for precise indication of hard signals, such as distinguishing between hot and open wires (to ground) in electrical installation applications.

WARNING:

● AutoCheck™ mode input impedance increases abruptly from initial 1.6kΩ to a few hundred kΩ's on high voltage hard signals. “**LoZ**” displays on the LCD to remind the users of being in such low impedance mode. Peak initial load current, while probing directly to 600VAC for example, can be up to 530mA ($600V \times 1.414 / 1.6k\Omega$), decreasing abruptly to approx. 4mA ($600V \times 1.414 / 210k\Omega$) within a fraction of a second. Do not use AutoCheck™ mode on circuits that could be damaged by such low input impedance. Instead, use slide-switch function selector $\text{Hz} \overline{\text{V}}$ common input impedance voltage modes (Hi-Z of approx. 5MΩ) to minimize loading for such circuits.

Manual or Auto-ranging

When the function selected has more than one range, press the **RANGE** button momentarily selects manual-ranging. The meter remains in the range it was in. The LCD annunciator **AUTO** turns off. Press the button momentarily again to step through the ranges. Press and hold the button for 1 second or more to resume auto-ranging.

Note:

*Manual-ranging feature is not available to **600Ω/•))** **→+/-** functions.

*To use Manual-ranging feature in AutoCheck™ mode, please see “Range-Lock Feature” as explained in footnotes of AutoCheck™ mode section.

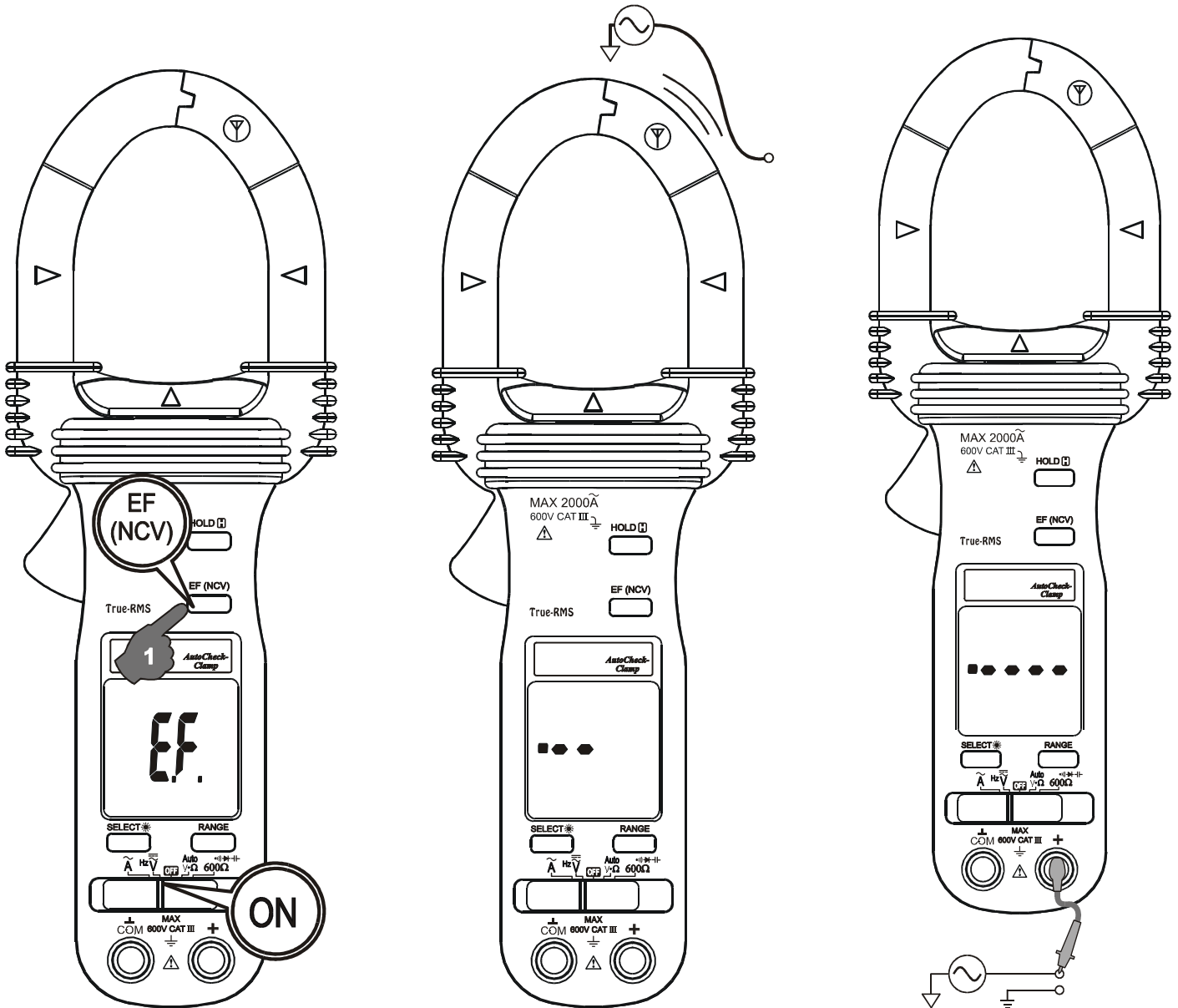

Electric Field EF-Detection

At any function, press the **EF (NCV)** button momentarily to toggle to EF-Detection feature. The meter displays “EF” when it is ready. Signal strength is indicated as a series of bar-graph segments on the display plus variable beep tones.

● **Non-Contact EF-Detection (NCV):** An antenna is located along the top of the stationary jaw (See Y symbol on the jaw), which detects electric field surrounds current-carrying conductors. It is ideal for tracing live wiring connections, locating wiring breakage and to distinguish between live or earth connections.

● **Probe-Contact EF-Detection:** For more precise indication of live wires, such as distinguishing between live and ground connections, use the Red (+) test probe for direct contact measurements.

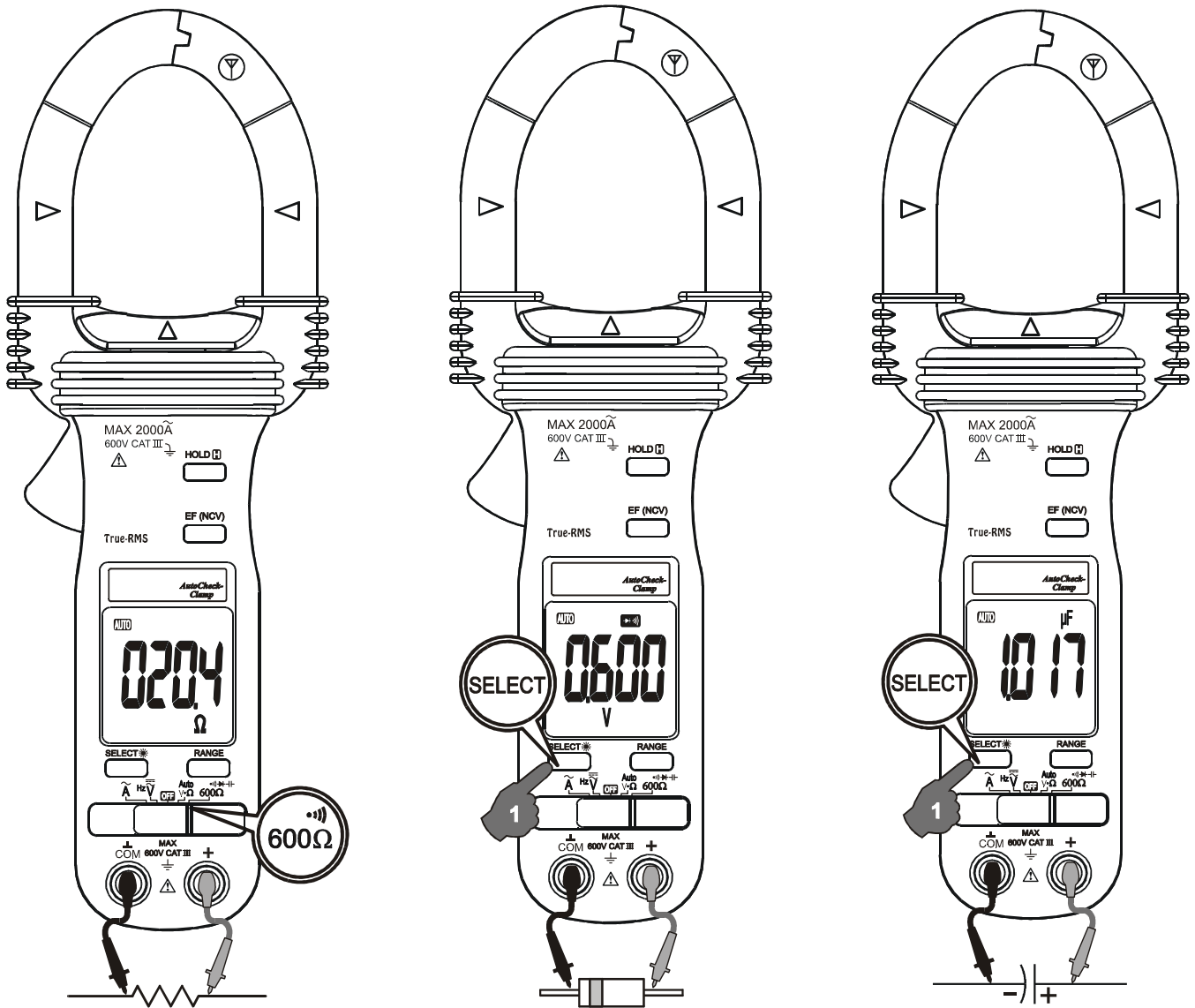

600Ω/•••) ➔/—|— functions

Set the slide-switch function selector to the **600Ω/•••) ➔/—|—** position.



- 600Ω Resistance range with Audible-Continuity is the default function. It is an extended low resistance range to complement the Resistance (Ω) function in AutoCheck™ mode. Audible-Continuity response time is also improved drastically (from that of AutoCheck™ mode) under such stand-alone range architecture. Audible-Continuity is convenient for checking wiring connections and operation of switches. A continuous beep tone indicates a complete circuit.

- Press **SELECT** button momentarily selects Diode test function. The reading shows the approximate voltage drop across the test leads. When forward biased, normal forward voltage drop for a good silicon diode is between 0.400V to 0.900V. A reading higher than that indicates a leaky diode (defective). A zero reading indicates a shorted diode (defective), and the meter gives a continuous beep warning. An OL indicates an open diode (defective). Reverse the test leads connections (reverse biased) across the diode. The display shows OL if the diode is good. Any other readings indicate the diode

is resistive or shorted (defective).

● Press **SELECT** button momentarily AGAIN selects Capacitance function. Capacitance measurement time varies with capacitance value. Only a few seconds is required for measuring values of below $100\mu\text{F}$. However, one minute or more is required for measuring extreme values of around $2000\mu\text{F}$.

HOLD feature

The Hold feature freezes the display for later viewing. Press the **HOLD**  button momentarily to toggle to the Hold feature. The annunciator "" turns on.

Backlighting display (model 118 only)

Press the **SELECT** button for 1 second or more to turn on or off the display backlight feature.

Auto Power Off (APO)

The meter turns off intelligently after approximately 3 minutes of neither significant measurement nor button/switch activity. To wake up the meter from APO, press any button or turn the rotary selector to OFF and back on again. Always turn the rotary selector to OFF when the meter is not in use.

5) MAINTENANCE

WARNING

To avoid electrical shock, disconnect the meter from any circuit, remove the test leads from the input jacks and turn OFF the meter before opening the case. Do not operate with open case.

Trouble Shooting

If the instrument fails to operate, check batteries and test leads etc., and replace as necessary. Double check operating procedure as described in this user's manual

If the instrument voltage-resistance input terminal has subjected to high voltage transient (caused by lightning or switching surge to the system) by accident or abnormal conditions of operation, the series fusible resistors will be blown off (become high impedance) like fuses to protect the user and the instrument. Most measuring functions through this terminal will then be open circuit. The series fusible resistors and the spark gaps should then be replaced by qualified technician. Refer to the LIMITED WARRANTY section for obtaining warranty or repairing service.

Cleaning and Storage

Periodically wipe the case with a damp cloth and mild detergent; do not use abrasives or solvents. If the meter is not to be used for periods of longer than 60 days, remove the batteries and store them separately

Battery replacement

The meter uses standard 1.5V AAA Size (NEDA 24A or IEC LR03) battery X 2

Loosen the 2 captive screws from the battery cover case. Lift the battery cover case. Replace the batteries. Replace battery cover case. Re-fasten the screws.

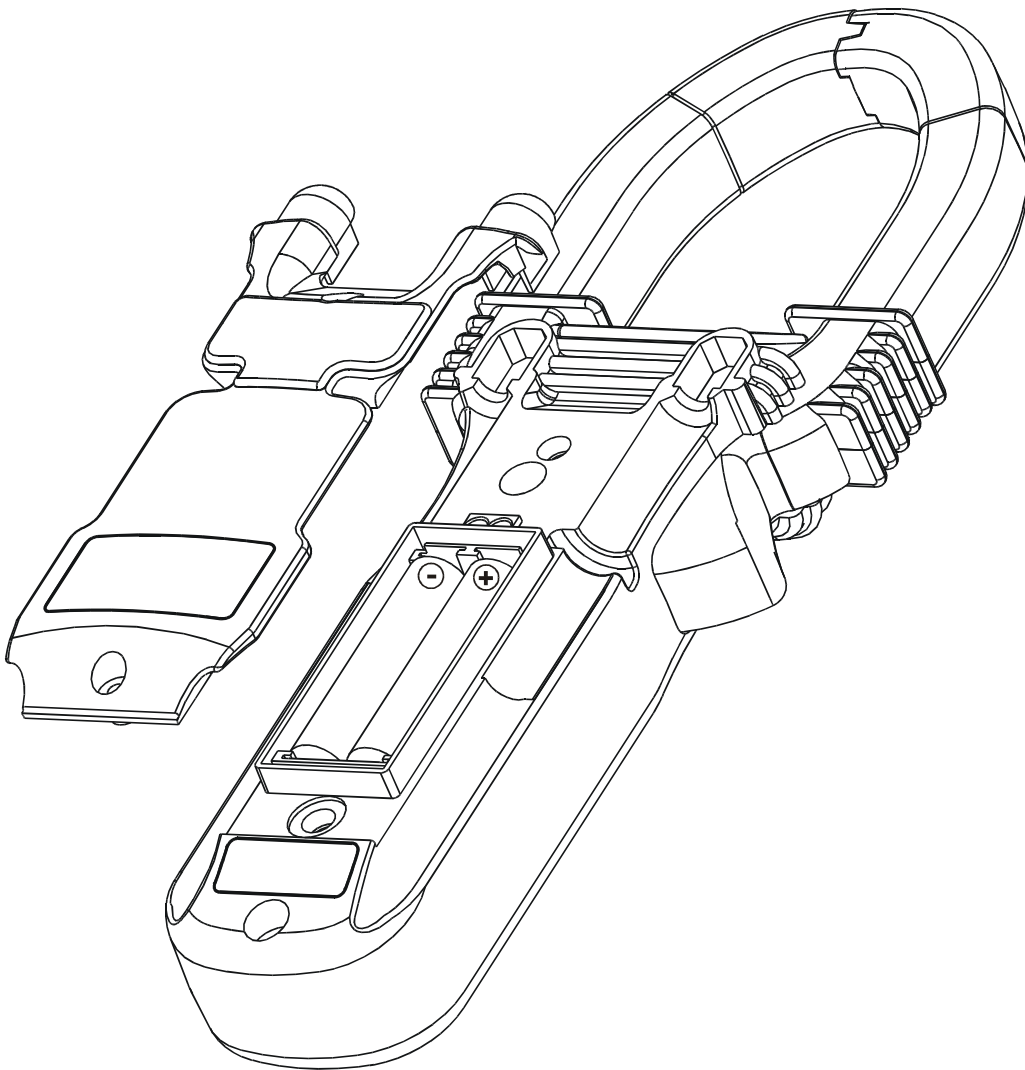

LIMITED WARRANTY

BRYMEN warrants to the original product purchaser that each product it manufactures will be free from defects in material and workmanship under normal use and service within a period of one year from the date of purchase. BRYMEN's warranty does not apply to accessories, fuses, fusible resistors, spark gaps, batteries or any product which, in BRYMEN's opinion, has been misused, altered, neglected, or damaged by accident or abnormal conditions of operation or handling.

To obtain warranty service, contact your nearest BRYMEN authorized agent or send the product, with proof of purchase and description of the difficulty, postage and insurance prepaid, to BRYMEN TECHNOLOGY CORPORATION. BRYMEN assumes no risk for damage in transit. BRYMEN will, at its option, repair or replace the defective product free of charge. However, if BRYMEN determines that the failure was caused by misused, altered, neglected, or damaged by accident or abnormal conditions of operation or handling, you will be billed for the repair.

THIS WARRANTY IS EXCLUSIVE AND IS IN LIEU OF ALL OTHER WARRANTIES, EXPRESSED OR IMPLIED, INCLUDING BUT NOT LIMITED TO ANY IMPLIED WARRANTY OR MERCHANTABILITY OR FITNESS FOR A PARTICULAR PURPOSE OR USE. BRYMEN WILL NOT BE LIABLE FOR ANY SPECIAL, INDIRECT, INCIDENTAL OR CONSEQUENTIAL DAMAGES.



BRYMEN TECHNOLOGY CORPORATION

TEL:+886 2 2226 3396

FAX:+886 2 2225 0025

<http://www.brymen.com>



PRINTED ON RECYCLABLE PAPER, PLEASE RECYCLE
COPYRIGHT © MMV Btc, ALL RIGHTS RESERVED

P/N:7M1C-0571-A000

PRINTED IN TAIWAN